



Item: \_\_\_\_\_

Quantity: \_\_\_\_\_

Project: \_\_\_\_\_

## Royal Series

**Models:**  RR-4  RR-2G12  RR-G24  RR-4SU  RR-2GT12  RR-GT24



RR-4 with optional casters

Gas Type:  Natural  LP

Elevation (if above 2000 ft.): \_\_\_\_\_

### Standard Features

- Stainless steel drip tray/grease can
- Accommodates 18" x 26" full sheet pan
- Stainless steel front, sides, valve cover and kick plate including backguard and high shelf
- Stainless Steel oven "U" burner rated at 27,000 BTU/hr
- Oven pilot with 100% safety shut down
- Two piece, heavy duty lift off cast iron burner heads rated at 30,000 BTU/hr each
- 12" x 12" cast iron top grates with pilot shield
- Solid welded heavy gauge metal frame
- Five position heavy gauge chrome rack guides
- One chrome rack per oven
- Five surface porcelain oven interior
- Stainless steel tubing for burners and pilots
- 3/4" thick polished steel griddle plate
- GT Griddle Series - standard with one thermostat per two burners
- SU - step up rear burners

### Options and Accessories

- 6" high S/S stub back in lieu of high shelf
- 1" thick griddle plate
- Griddle on right (Left hand side standard)
- Chrome griddle plate
- Grooved griddle (specify width: \_\_\_\_\_")
- One thermostat per burner (GT Griddle Series)
- 12" hot top section - add suffix "-HT"
- 9" deep S/S landing ledge, with or without sauce pan cutouts
- Additional oven racks
- Open storage cabinet base - add suffix "-XB"
- Cabinet doors
- Intermediate shelf
- Wok burner head with 10" diameter S/S ring
- 48" quick disconnect and restraining cable
- 5" swivel casters (set of four - 2 locking)



**2 YEAR LIMITED, PARTS AND LABOR WARRANTY**

# 24" Gas Restaurant Range

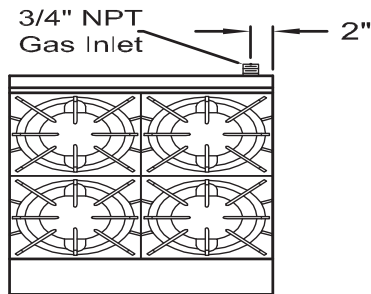
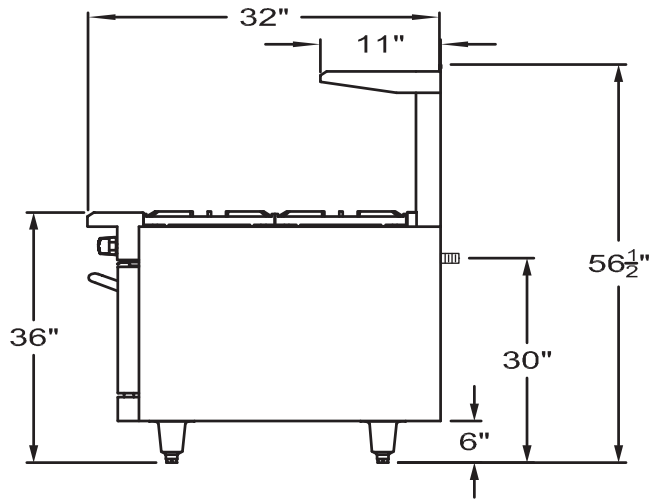
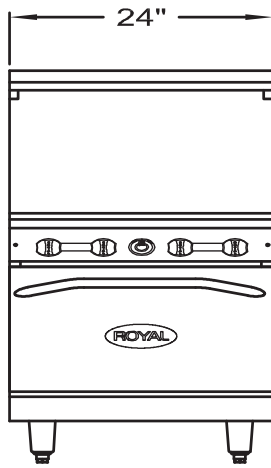

RR-4

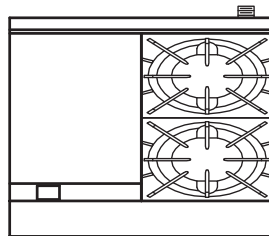

RR-2G12

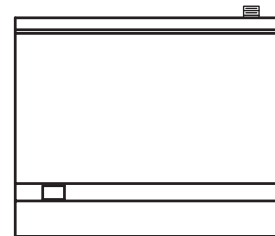

RR-G24

Model Number	Open Burners	Griddle Burners	Total BTU	Ship Weight
RR-4	4	0	147,000	400 lbs.
RR-2G(T)12	2	1	107,000	420 lbs.
RR-G(T)24	0	2	67,000	440 lbs.
RR-4SU	4	0	147,000	410 lbs.

**Notes:**

- For no oven (storage base) add suffix "-XB" and deduct 27,000 BTUs.
- Open burners at 30,000 BTU/hr each.
- Griddle Burners: 1 per 12" at 20,000 BTU/hr each.
- Oven burners at 27,000 BTU/hr.

**Gas Connection:**

3/4" NPT on the right hand rear of the appliance.

The pressure regulator (supplied) is to be connected by the installer.

**Gas Pressure:**

5" W.C.	Natural Gas
10" W.C.	Propane

**Clearances:**

	Combustible	Non-Combustible
Rear	4"	0"
Sides	15"	0"

Specify type of gas and altitude, if over 2,000 feet, when ordering.

Due to continuing product development to ensure best possible performance, these specifications are subject to change without prior notification.

[www.southernice.com](http://www.southernice.com)

Lafayette, Louisiana- 337-235-5813



New Orleans, Louisiana- 504-734-5024

Little Rock, Arkansas- 501-569-9318

Jackson, Mississippi- 601-923-3332

Phoenix, Arizona- 602-470 2366

Albuquerque, New Mexico- 505-247-0330 Houston, Texas- 713-742-9010