

Undercounter Ice Machines

Technician's Handbook

This manual is updated as new information and models are released. Visit our website for the latest manual.

www.kool-aire.com



Safety Notices

Read these precautions to prevent personal injury:

- Read this manual thoroughly before operating, installing or performing maintenance on the equipment. Failure to follow instructions in this manual can cause property damage, injury or death.
- Routine adjustments and maintenance procedures outlined in this manual are not covered by the warranty.
- Proper installation, care and maintenance are essential for maximum performance and trouble-free operation of your equipment.
- Visit our website www.kool-aire.com for manual updates, translations, or contact information for service agents in your area.
- This equipment contains high voltage electricity and refrigerant charge. Installation and repairs are to be performed by properly trained technicians aware of the dangers of dealing with high voltage electricity and refrigerant under pressure. The technician must also be certified in proper refrigerant handling and servicing procedures. All lockout and tag out procedures must be followed when working on this equipment.
- This equipment is intended for indoor use only. Do not install or operate this equipment in outdoor areas.
- As you work on this equipment, be sure to pay close attention to the safety notices in this handbook. Disregarding the notices may lead to serious injury and/or damage to the equipment.

Warning

Follow these electrical requirements during installation of this equipment.

- All field wiring must conform to all applicable codes of the authority having jurisdiction. It is the responsibility of the end user to provide the disconnect means to satisfy local codes. Refer to rating plate for proper voltage.
- This appliance must be grounded.
- This equipment must be positioned so that the plug is accessible unless other means for disconnection from the power supply (e.g., circuit breaker or disconnect switch) is provided.
- Check all wiring connections, including factory terminals, before operation. Connections can become loose during shipment and installation.

Warning

Follow these precautions to prevent personal injury during installation of this equipment:

- Installation must comply with all applicable equipment fire and health codes with the authority having jurisdiction.
- To avoid instability the installation area must be capable of supporting the combined weight of the equipment and product. Additionally the equipment must be level side to side and front to back.
- Ice machines require a deflector when installed on an ice storage bin. Prior to using a non-OEM ice storage system with this ice machine, contact the bin manufacturer to assure their ice deflector is compatible.
- Remove all removable panels before lifting and installing and use appropriate safety equipment during installation and servicing. Two or more people are required to lift or move this appliance to prevent tipping and/or injury.
- Do not damage the refrigeration circuit when installing, maintaining or servicing the unit.
- Connect to a potable water supply only.
- This equipment contains refrigerant charge.
- Installation of the line sets must be performed by a properly trained and EPA certified refrigeration technician aware of the dangers of dealing with refrigerant charged equipment.

Warning

Follow these precautions to prevent personal injury while operating or maintaining this equipment.

- Legs or casters must be installed and the legs/casters must be screwed in completely. When casters are installed the mass of this unit will allow it to move uncontrolled on an inclined surface. These units must be tethered/secured to comply with all applicable codes. Swivel casters must be mounted on the front and rigid casters must be mounted on the rear. Lock the front casters after installation is complete.
- Some 50 Hz models may contain up to 150 grams of R290 (propane) refrigerant. R290 (propane) is flammable in concentrations of air between approximately 2.1% and 9.5% by volume (LEL lower explosion limit and UEL upper explosion limit). An ignition source at a temperature higher than 470°C is needed for a combustion to occur.
- Refer to nameplate to identify the type of refrigerant in your equipment.
- Only trained and qualified personnel aware of the dangers are allowed to work on the equipment.
- Read this manual thoroughly before operating, installing or performing maintenance on the equipment. Failure to follow instructions in this manual can cause property damage, injury or death.
- Crush/Pinch Hazard. Keep hands clear of moving components. Components can move without warning unless power is disconnected and all potential energy is removed.
- Moisture collecting on the floor will create a slippery surface. Clean up any water on the floor immediately to prevent a slip hazard.

Warning

Follow these precautions to prevent personal injury while operating or maintaining this equipment.

- Objects placed or dropped in the bin can affect human health and safety. Locate and remove any objects immediately.
- Never use sharp objects or tools to remove ice or frost.
- Do not use mechanical devices or other means to accelerate the defrosting process.
- When using cleaning fluids or chemicals, rubber gloves and eye protection (and/or face shield) must be worn.

DANGER

Do not operate equipment that has been misused, abused, neglected, damaged, or altered/modified from that of original manufactured specifications. This appliance is not intended for use by persons (including children) with reduced physical, sensory or mental capabilities, or lack of experience and knowledge, unless they have been given supervision concerning use of the appliance by a person responsible for their safety. Do not allow children to play with, clean or maintain this appliance without proper supervision.

Follow these precautions to prevent personal injury during use and maintenance of this equipment:

- It is the responsibility of the equipment owner to perform a Personal Protective Equipment Hazard Assessment to ensure adequate protection during maintenance procedures.
- Do Not Store Or Use Gasoline Or Other Flammable Vapors Or Liquids In The Vicinity Of This Or Any Other
- Appliance. Never use flammable oil soaked cloths or combustible cleaning solutions for cleaning.
- All covers and access panels must be in place and properly secured when operating this equipment.
- Risk of fire/shock. All minimum clearances must be maintained. Do not obstruct vents or openings.
- Failure to disconnect power at the main power supply disconnect could result in serious injury or death. The power switch DOES NOT disconnect all incoming power.
- All utility connections and fixtures must be maintained in accordance with the authority having jurisdiction.
- Turn off and lockout all utilities (gas, electric, water) according to approved practices during maintenance or servicing.
- Units with two power cords must be plugged into individual branch circuits. During movement, cleaning or repair it is necessary to unplug both power cords.

We reserve the right to make product improvements at any time. Specifications and design are subject to change without notice.

Table of Contents

General Information

Model Numbers	13
How to Read a Model Number	14
Accessories	14
Bin Caster	14
Cleaner and Sanitizer	14
Model/Serial Number Location	15
Ice Machine Warranty Information	15

Installation

Location of Ice Machine	17
Ice Machine Clearance Requirements	18
Ice Machine Heat of Rejection	18
Leveling the Ice Machine	19
Electrical Requirements	20
Voltage	20
Fuse/Circuit Breaker	20
Total Circuit Ampacity	20
Electrical Specifications	21
Air-cooled Ice Machine	21
Water-cooled Ice Machines	21
Water Service/Drains	22
Water Supply	22
Water Inlet Lines	22
Drain Connections	22
Water Supply and Drain Line Sizing/ Connections	23
Cooling Tower Applications	24

Component Identification

Evaporator Compartment	25
-------------------------------------	----

Maintenance

Ice Machine Inspection	27
Exterior Cleaning	27
Cleaning the Condenser	27
Interior Cleaning and Sanitizing.....	29

Removal from Service/Winterization	42
---	-----------

Operation

Initial Start-up or Start-up After Automatic Shut-off.....	45
Freeze Sequence	45
Harvest Sequence	46
Automatic Shut-off	46
Energized Parts Chart.....	47

Operational Checks	49
---------------------------------	-----------

Troubleshooting

Diagnosing an Ice Machine that Will Not Run	53
Diagnosing Ice Thickness Control Circuitry .	54
Ice Production Check.....	57
Installation and Visual Inspection Checklist.	59
Water System Checklist.....	60
Ice Formation Pattern.....	61
Safety Limit Feature	63
Analyzing Discharge Pressure	70
Analyzing Suction Pressure	72
Harvest Valve.....	76
Comparing Evaporator Inlet/Outlet Temperatures	80
Discharge Line Temperature Analysis.....	81
Refrigeration Component Diagnostic Chart	83
Procedure.....	84
Final Analysis.....	85
Refrigeration Component Diagnostic Chart	86
Ice Quality Is Poor — Cubes are Shallow, Incomplete or White.....	89
Freeze Cycle Is Long, Low Ice Production ...	90
Ice Machine Runs and No Ice Is Produced...	91

Component Check Procedures

Main Fuse	93
Bin Switch	94
Diagnosing Start Components	97
Capacitor	97
Relay	97
ON/OFF/WASH Toggle Switch	98
Ice Thickness Probe	99
Ice Thickness Check	100
Compressor Electrical Diagnostics	101
Fan Cycle Control	103
High Pressure Cutout (HPCO) Control	104
Filter-Driers	105
Refrigerant Recovery/Evacuation	106
Refrigerant Re-use Policy	107
Recovery and Recharging Procedures	109
System Contamination Cleanup	112
Mild System Contamination Cleanup Procedure	114
Severe System Contamination Cleanup Procedure	115
Replacing Pressure Controls without Removing Refrigerant Charge	117
KF250/K270 Condenser Fan Motor Access ...	119

Component Specifications

Main Fuse	121
Bin Switch	121
ON/OFF/WASH Toggle Switch	121
Fan Control Cycle	121
High Pressure Cutout (HPCO) Control	121
Filter-Driers	121
Total System Refrigerant Charge	122

Charts

Cycle Times, 24 Hr. Ice Production and Refrigerant Pressure Charts	123
KF0150A self-contained Air-Cooled	124
K170A Self-contained Air-cooled	125
KF0250 Self-contained Air-cooled	126
K270 Self-contained Air-cooled	127

Diagrams

Wiring Diagrams	129
KF150/K170 Wiring Diagram	130
KF250/K270 Wiring Diagram	132
Electronic Control Board	134
KF150/K170/KF250/K270 Tubing Schematic	134

General Information

Model Numbers

This manual covers the following models:

Self-contained Air-cooled	Self-contained Water-cooled
KDF0150A	N/A
KYF0150A	N/A
KD0172A	N/A
KY0174A	N/A
KDF0250A	N/A
KYF0250A	N/A
KR0270A	KR0271W
KD0272A	KD0273W
KY0274A	KY0275W

Warning

An ice machine contains high voltage electricity and refrigerant charge. Repairs are to be performed by properly trained refrigeration technicians aware of the dangers of dealing with high voltage electricity and refrigerant under pressure.

How to Read a Model Number

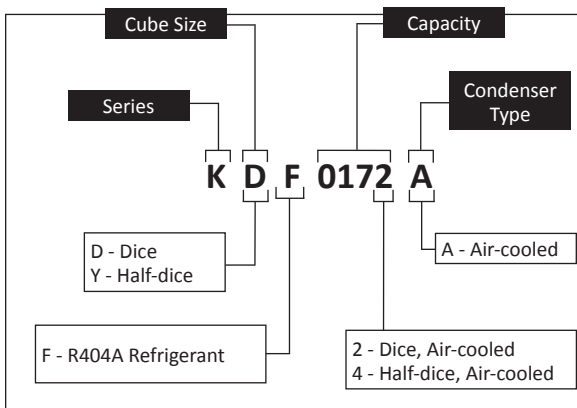

Accessories

Contact your distributor for these optional accessories:

BIN CASTER

Replaces standard legs.

CLEANER AND SANITIZER

Manitowoc Ice Machine Cleaner and Sanitizer are available in convenient 16 oz. (473 ml) and 1 gal (3.78 l) bottles. These are the only cleaner and sanitizer approved for use with Koolaire® products.

Cleaner Part Number	Sanitizer Part Number
16 oz 94-0456-3	16 oz 94-0565-3
1 Gallon 4-0580-3	1 Gallon 94-0581-3

Model/Serial Number Location

The model and serial numbers are required when requesting information from your local distributor, service representative, or Welbilt KitchenCare®. The model and serial number are listed on the OWNER WARRANTY REGISTRATION CARD. They are also listed on the MODEL/SERIAL NUMBER DECAL affixed to the ice machine.

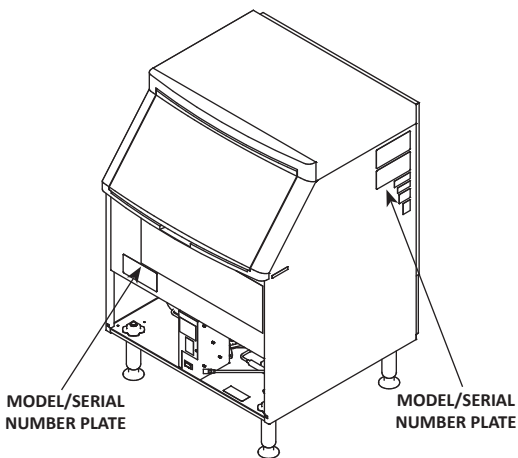

SV1687G

Model/Serial Number Location

Ice Machine Warranty Information

For warranty information visit:

<http://www.kool-aire.com/Service/Warranty>

- Warranty Verification
- Warranty Registration
- View and download a copy of the warranty

THIS PAGE INTENTIONALLY LEFT BLANK

Installation

Location of Ice Machine

The location selected for the ice machine must meet the following criteria. If any of these criteria are not met, select another location.

- The location must be indoors.
- The location must be free of airborne and other contaminants.
- Air temperature:
 - Must be at least 40°F (4°C) but must not exceed 110°F (43.4°C).
- The location must not be near heat-generating equipment or in direct sunlight.
- The location must be capable of supporting the weight of the ice machine and a full bin of ice.
- The location must allow enough clearance for water, drain, and electrical connections in the **rear of the ice machine**.
- The location must not obstruct airflow through or around the ice machine (condenser airflow is in and out the front). Refer to the chart below for clearance requirements.
- The ice machine must be protected if it will be subjected to temperatures below 32°F (0°C). Failure caused by exposure to freezing temperatures is not covered by the warranty.

Ice Machine Clearance Requirements

Self-contained Air-cooled	
Top/Sides	5" (127 mm)*
Back	5" (127 mm)*

*NOTE: The ice machine may be built into a cabinet.

There is no minimum clearance requirement for the top or left and right sides of the ice machine. The listed values are recommended for efficient operation and servicing only.

Ice Machine Heat of Rejection

Series Ice Machine	Heat of Rejection*	
	Air Conditioning**	Peak
KF150	2200	2600
K170	2200	2600
KF250	3800	6000
K270	3800	6000

* B.T.U./Hour

** Because the heat of rejection varies during the ice making cycle, the figure shown is an average.

Ice machines, like other refrigeration equipment, reject heat through the condenser. It is helpful to know the amount of heat rejected by the ice machine when sizing air conditioning equipment where self-contained air-cooled ice machines are installed.

Leveling the Ice Machine

1. Screw the leveling legs onto the bottom of the ice machine.
2. Screw the foot of each leg in as far as possible.

Caution

The legs must be screwed in tightly to prevent them from bending.

3. Move the ice machine into its final position.
4. Level the ice machine to ensure that the siphon system functions correctly. Use a level on top of the ice machine. Turn each foot as necessary to level the ice machine from front to back and side to side.

NOTE: An optional 2-1/2" (6.35 cm) caster assembly is available for use in place of the legs. Installation instructions are supplied with the casters.

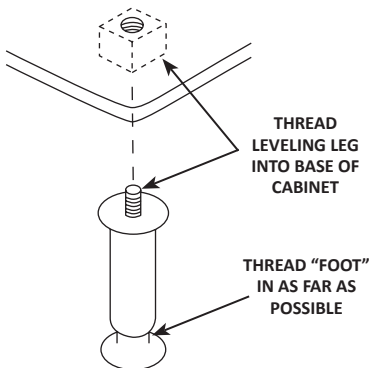

SV1606

Leg Installation

Electrical Requirements

VOLTAGE

The maximum allowable voltage variation is $\pm 10\%$ of the rated voltage on the ice machine model/serial number plate at start-up (when the electrical load is highest).

The 115/1/60 ice machines are factory pre-wired with a 6' (1.8 m) power cord, and NEMA 5-15P-plug configuration.

The 208-230/1/60 and 230/1/50 ice machines are factory pre-wired with a power cord only, no plug is supplied.

FUSE/CIRCUIT BREAKER

A separate fuse/circuit breaker must be provided for each ice machine. Circuit breakers must be H.A.C.R. rated (does not apply in Canada).

TOTAL CIRCUIT AMPACITY

The total circuit ampacity is used to help select the wire size of the electrical supply.

The wire size (or gauge) is also dependent upon location, materials used, length of run, etc., so it must be determined by a qualified electrician.

Electrical Specifications

AIR-COOLED ICE MACHINE

Ice Machine	Voltage Phase Cycle	Max. Fuse/ Circuit Breaker	Total Amps
KF150	115/60/1	15 amp	7.4
K170	115/1/60	15 amp	7.0
	208/1/60	15 amp	3.5
	230/1/50	15 amp	4.0
KF250	115/60/1	15 amp	11.8
K270	115/1/60	15 amp	10.7
	208-230/1/60	15 amp	5.2
	230/1/50	15 amp	5.2

Warning

All wiring must conform to local, state and national codes.

Warning

The ice machine must be grounded in accordance with national and local electrical code.

WATER-COOLED ICE MACHINES

Ice Machine	Voltage Phase Cycle	Max. Fuse/ Circuit Breaker	Total Amps
K170	115/1/60	15 amp	6.3
	208/1/60	15 amp	3.6
	230/1/50	15 amp	4.0
K270	115/1/60	15 amp	9.9
	208-230/1/60	15 amp	4.7
	230/1/50	15 amp	4.7

Water Service/Drains

WATER SUPPLY

Local water conditions may require treatment of the water to inhibit scale formation, filter sediment, and remove chlorine odor and taste.

Important

If you are installing a water filter system, refer to the Installation Instructions supplied with the filter system for ice making water inlet connections.

WATER INLET LINES

Follow these guidelines to install water inlet lines:

- Do not connect the ice machine to a hot water supply. Be sure all hot water restrictors installed for other equipment are working. (Check valves on sink faucets, dishwashers, etc.)
- If water pressure exceeds the maximum recommended pressure, 80 psig (5.5 bar) obtain a water pressure regulator from your distributor.
- Install a water shut-off valve for ice making potable water.
- Insulate water inlet lines to prevent condensation.

DRAIN CONNECTIONS

Follow these guidelines when installing drain lines to prevent drain water from flowing back into the ice machine and storage bin:

- Drain lines must have a 1.5-inch drop per 5 feet of run (2.5 cm per meter), and must not create traps.
- The floor drain must be large enough to accommodate drainage from all drains.
- Run separate bin and ice machine drain lines. Insulate them to prevent condensation.
- Vent the bin and ice machine drain to the atmosphere.

WATER SUPPLY AND DRAIN LINE SIZING/ CONNECTIONS

Bin Drain	Condenser Water Drain	Condenser Water Inlet	Ice Making Water Inlet	Location
—	—	33°F (0.6°C) min. 90°F (32.2°C) max.	40°F (4°C) min. 90°F (32.2°C) max.	Water Temperature
—	—	20 psi (1.38 bar) min. 150 psi (10.3 bar) max.	20 psi (1.38 bar) min. 80 psi (5.5 bar) max.	Water Pressure
1/2" Female Pipe Thread	3/8" Female Pipe Thread	3/8" Female Pipe Thread	3/8" Female Pipe Thread	Ice Machine Fitting
1/2" (12.7 mm) min. inside diameter	3/8" (9.5 mm) min. inside diameter	3/8" (9.5 mm) min. inside diameter	3/8" (9.5 mm) min. inside diameter	Tubing Size Up to Ice Machine Fitting

COOLING TOWER APPLICATIONS

Water Cooled Models Only

A water-cooling tower installation does not require modification of the ice machine. The water regulator valve for the condenser continues to control the refrigeration discharge pressure.

It is necessary to know the amount of heat rejected, and the pressure drop through the condenser and water valves (inlet to outlet) when using a cooling tower on an ice machine.

- Water entering the condenser must not exceed 90°F (32.2°C).
- Water flow through the condenser must not exceed 5 gallons (19 liters) per minute.
- Allow for a pressure drop of 7 psig (.48 bar) between the condenser water inlet and the outlet of the ice machine.
- Water exiting the condenser must not exceed 110°F (43.3°C).

 **Caution**

Plumbing must conform to state and local codes.

Component Identification

Evaporator Compartment

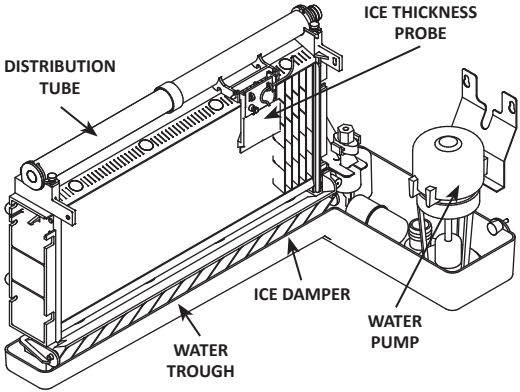

SV1694A

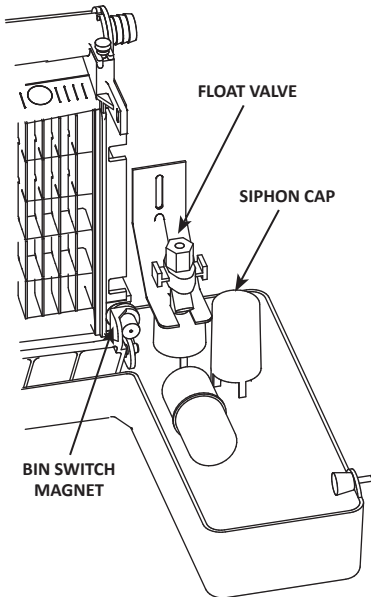

SV1695A

Evaporator Compartment

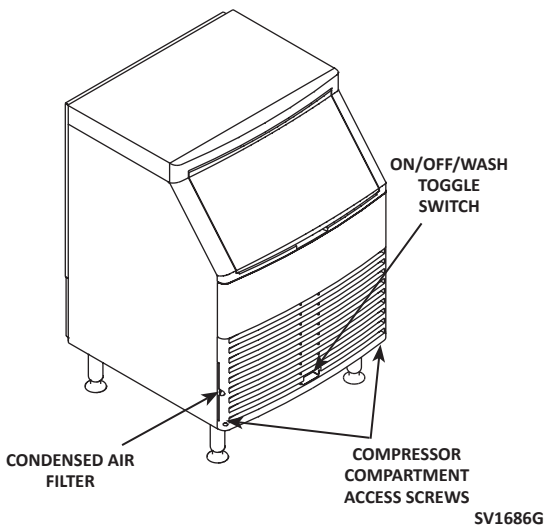

KF150/K170 Ice Machines

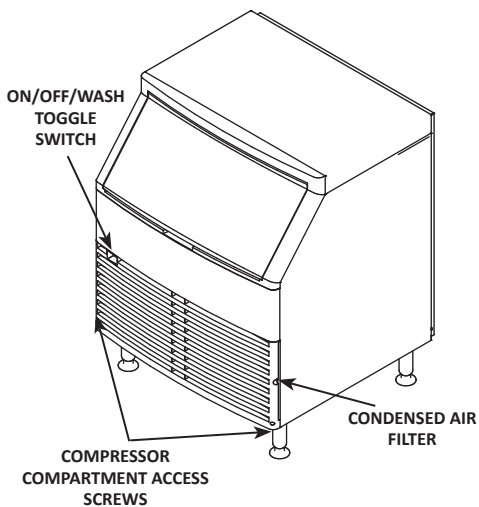

KF250/K270 Ice Machines

Maintenance

ICE MACHINE INSPECTION

Check all water fittings and lines for leaks. Also, make sure the refrigeration tubing is not rubbing or vibrating against other tubing, panels, etc.

Do not put anything (boxes, etc.) in front of the ice machine. There must be adequate airflow through and around the ice machine to maximize ice production and ensure long component life.

EXTERIOR CLEANING

Clean the area around the ice machine as often as necessary to maintain cleanliness and efficient operation.

Sponge any dust and dirt off the outside of the ice machine with mild soap and water. Wipe dry with a clean, soft cloth.

A commercial grade stainless steel cleaner/polish can be used as necessary.

CLEANING THE CONDENSER

Warning

Disconnect electric power to the ice machine at the electric service switch before cleaning the condenser.

Caution

If you are cleaning the condenser fan blades with water, cover the fan motor to prevent water damage.

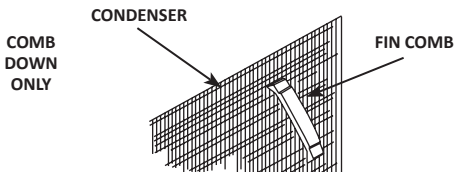

Air-cooled Condenser

A dirty condenser restricts airflow, resulting in excessively high operating temperatures. This reduces ice production and shortens component life. Clean the condenser at least every six months. Follow the steps below.

Warning

The condenser fins are sharp. Use care when cleaning them.

1. The washable aluminum filter on self-contained air-cooled ice machines is designed to catch dust, dirt, lint and grease. This helps keep the condenser clean. Clean the filter with a mild soap and water solution.
2. Clean the outside of the condenser with a soft brush or a vacuum with a brush attachment. Clean from top to bottom, not side to side. Be careful not to bend the condenser fins.
3. Shine a flashlight through the condenser to check for dirt between the fins. If dirt remains:
 - A. Blow compressed air through the condenser fins from the inside. Be careful not to bend the fan blades.
 - B. Use a commercial condenser coil cleaner. Follow the directions and cautions supplied with the cleaner.
4. Straighten any bent condenser fins with a fin comb.
5. Carefully wipe off the fan blades and motor with a soft cloth. Do not bend the fan blades. If the fan blades are excessively dirty, wash with warm, soapy water and rinse thoroughly.

INTERIOR CLEANING AND SANITIZING

General

Clean and sanitize the ice machine every six months for efficient operation. If the ice machine requires more frequent cleaning and sanitizing, consult a qualified service company to test the water quality and recommend appropriate water treatment.

The ice machine must be taken apart for cleaning and sanitizing.

Caution

Use only Manitowoc Ice Machine Cleaner (part number 95-0546-3) and Sanitizer (part number 94-0565-3). It is a violation of Federal law to use these solutions in a manner inconsistent with their labeling. Read and understand all labels printed on bottles before use.

Cleaning and Sanitizing Procedure

Caution

Do not mix Ice Machine Cleaner and Sanitizer solutions together. It is a violation of Federal law to use these solutions in a manner inconsistent with their labeling.

Warning

Wear rubber gloves and safety goggles (and/or face shield) when handling Ice Machine Cleaner or Sanitizer.

Ice machine cleaner is used to remove lime scale and mineral deposits. Ice machine sanitizer disinfects and removes algae and slime.

Step 1 Set the toggle switch to the OFF position after ice falls from the evaporator at the end of a Harvest cycle. Or, set the switch to the OFF position and allow the ice to melt off the evaporator.

 **Caution**

Never use anything to force ice from the evaporator. Damage may result.

Step 2 Remove all ice from the bin.

Step 3 To start a cleaning cycle, move the toggle switch to the WASH position.

Step 4 Add the proper amount of Ice Machine Cleaner to the water trough.

Model	Amount of Cleaner
KF150 K170	2 ounces (60 ml)
KF250 K270	2 ounces (60 ml)

Step 5 Wait until the clean cycle is complete (approximately 22 minutes) then place the toggle switch in the OFF position, disconnect power and water supplies to the ice machine.

 **Warning**

Disconnect electric power to the ice machine at the electric switch box before proceeding.

Step 6 Remove parts for cleaning.

A. Remove Two Thumbscrews and Water Pump Cover (When Used).

B. Remove the Vinyl Hose Connecting the Water Pump and Water Distribution Tube

C. Remove Water Pump

- Disconnect the water pump power cord
- Loosen the screws securing the pump-mounting bracket to the bulkhead
- Lift the pump and bracket assembly off the mounting screws.

WHEN USED - REMOVE
THUMBSCREWS AND
WATER PUMP COVER

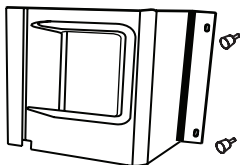

DO NOT SOAK WATER
PUMP MOTOR IN CLEANER
OR SANITIZER SOLUTION

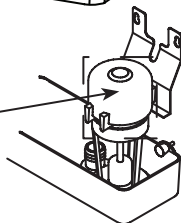

Water Pump Removal

D. Remove the Ice Thickness Probe

- Compress the side of the ice thickness probe near the top hinge pin and remove it from the bracket.

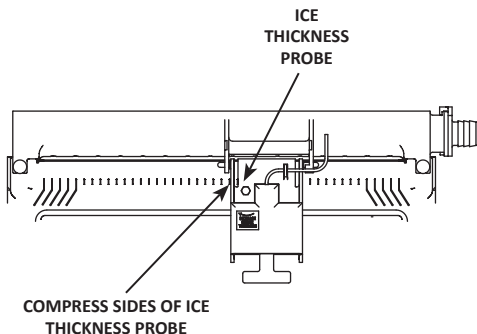

SV1138A

Ice Thickness Probe Removal

NOTE: At this point, the ice thickness probe can easily be cleaned. If complete removal is desired, follow the ice thickness probe wire to the bulkhead grommet (exit point) in the back wall. Pop the bulkhead grommet out of the back wall by inserting fingernails or a flat object between the back wall and the grommet and prying forward. Pull the bulkhead grommet and wire forward until the connector is accessible, then disconnect the wire lead from the connector.

Ice Thickness Probe Cleaning

- Mix a solution of ice machine cleaner and water (2 ounces of cleaner to 16 ounces of water) in a container.
- Soak the ice thickness probe a minimum of 10 minutes.

Clean all ice thickness probe surfaces and verify the ice thickness probe cavity is clean. Rinse thoroughly with clean water, then dry completely. Incomplete rinsing and drying of the ice thickness probe can cause premature harvest.

E. Remove the Water Distribution Tube

1. LIFT UP
2. SLIDE BACK
3. SLIDE TO RIGHT

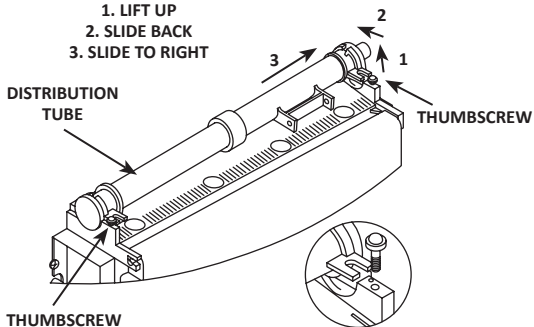

SV1630

Water Distribution Tube Removal

- Loosen the two thumbscrews, which secure the distribution tube.
- Lift the right side of the distribution tube up off the locating pin, then slide it back and to the right.

Caution

Do not force this removal. Be sure the locating pin is clear of the hole before sliding the distribution tube out.

Disassembly

- Twist both of the inner tube ends until the tabs line up with the keyway.
- Pull the inner tube ends outward.

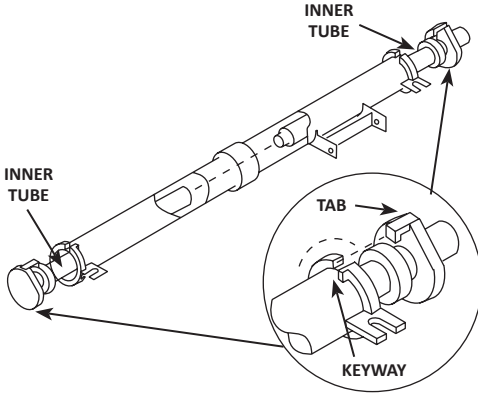

SV1211

Water Distribution Tube Disassembly

F. Remove the Float Valve

- Turn the splash shield counterclockwise one or two turns.

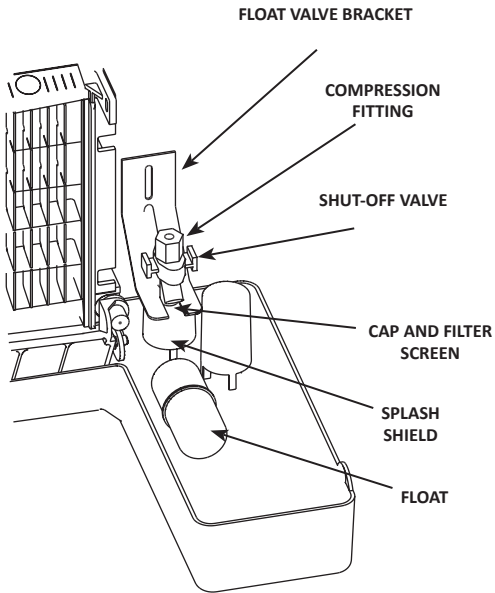

SV1695-2

Float Valve Removal

- Pull the float valve forward and off the mounting bracket.
- Disconnect the water inlet tube from the float valve at the compression fitting.
- Remove the cap and filter screen for cleaning.

G. Remove the Water Trough

- Apply downward pressure on the siphon tube and remove from the bottom of the water trough.
- Remove the upper thumbscrew.
- While supporting the water trough remove the two thumbscrews from beneath the water trough.
- Remove the water trough from the bin area.

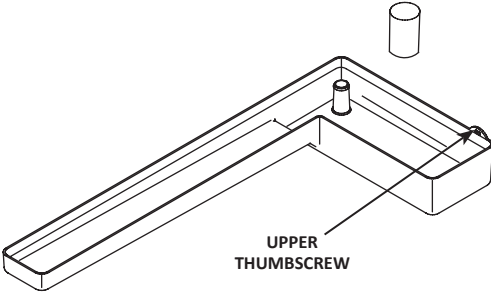

SV1689-1

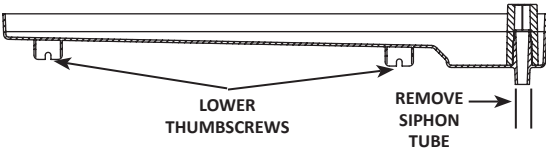

SV1689-2

Remove the Ice Damper

H. Remove the ice damper

- Grasp ice damper and apply pressure toward the left-hand mounting bracket.
- Apply pressure to the right-hand mounting bracket with thumb.
- Pull ice damper forward when the right-hand ice damper pin disengages.

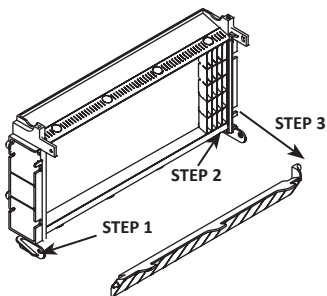

SV1742A

Installation

- Place ice damper pin in left-hand mounting bracket and apply pressure toward the left-hand mounting bracket.
- Apply pressure to the right-hand mounting bracket with thumb.
- Push ice damper toward evaporator until right-hand damper pin engages.

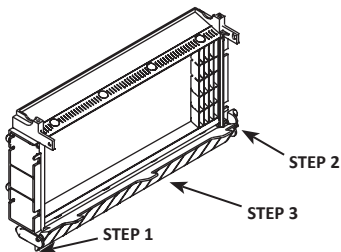

SV1742H

Remove the Bin Door

- Grasp the rear of the bin door and pull bin door forward approximately 5".
- Slide bin door to the rear while applying upward pressure (The rear door pins will ride up into the track slot and slide backward to the stop tab).
- While applying pressure against the bin door pull down on the rear of each bin door track until the door pins clear the stop tabs.
- Slide the rear door pins off the end and then below the door track. Slide bin door forward allowing the back of the door to lower into the bin. Continue forward with the bin door until the front pins bottom out in the track.
- Lift right side of door until the front pins clear the track, then remove door from bin.
- Remove rollers (4) from all door pins.

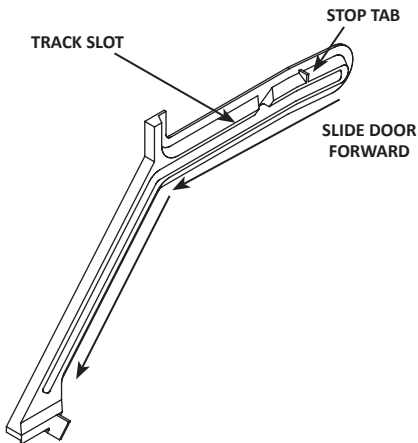

SV1748

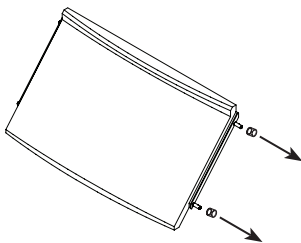

Step 7 Mix a solution of cleaner and warm water. Depending on the amount of mineral buildup, a larger quantity of solution may be required. Use the ratio in the table below to mix enough solution to thoroughly clean all parts.

Solution Type	Water	Mixed with
Cleaner	1 gal. (4 l)	16 oz (500 ml) cleaner

Step 8 Use 1/2 of the cleaner/water solution to clean all components. The cleaner solution will foam when it contacts lime scale and mineral deposits; once the foaming stops use a soft bristle brush, sponge or cloth (not a wire brush) to carefully clean the parts. Soak the parts for 5 minutes (15 – 20 minutes for heavily scaled parts). Rinse all components with clean water.

Step 9 While components are soaking, use 1/2 of the cleaner/water solution to clean all foodzone surfaces of the ice machine and bin. Use a nylon brush or cloth to thoroughly clean the following ice machine areas:

- Evaporator plastic parts – including top, bottom and sides
- Bin bottom, sides and top

Rinse all areas thoroughly with clean water.

Step 10 Mix a solution of sanitizer and warm water.

Solution Type	Water	Mixed With
Sanitizer	6 gal. (23 l)	4 oz (120 ml) sanitizer

Step 11 Use 1/2 of the sanitizer/water solution to sanitize all removed components. Use a cloth or sponge to liberally apply the solution to all surfaces of the removed parts or soak the removed parts in the sanitizer/water solution. Do not rinse parts after sanitizing.

Step 12 Use 1/2 of the sanitizer/water solution to sanitize all foodzone surfaces of the ice machine and bin. Use a cloth or sponge to liberally apply the solution. When sanitizing, pay particular attention to the following areas:

- Evaporator plastic parts - including top, bottom and sides
- Bin bottom, sides and top

Do not rinse the sanitized areas.

Step 13 Replace all removed components.

Step 14 Reapply power and water to the ice machine and place the toggle switch in the WASH position.

Add the proper amount of Ice Machine Sanitizer to the water trough.

Model	Amount of Sanitizer
KF150 K170	2.2 ounces (66 ml)
KF250 K270	1.9 ounces (57 ml)

Step 15 Wait until the sanitize cycle is complete (approximately 22 minutes) then place the toggle switch in the OFF position, disconnect power and water supplies to the ice machine.

 Warning

Disconnect electric power to the ice machine at the electric switch box before proceeding.

Step 16 Repeat step 6 to remove parts for hand sanitizing.

Step 17 Mix a solution of sanitizer and warm water.

Solution Type	Water	Mixed With
Sanitizer	6 gal. (23 l)	4 oz (120 ml) sanitizer

Step 18 Use 1/2 of the sanitizer/water solution to sanitize all removed components. Use a cloth or sponge to liberally apply the solution to all surfaces of the removed parts or soak the removed parts in the sanitizer/water solution. Do not rinse parts after sanitizing.

Step 19 Use 1/2 of the sanitizer/water solution to sanitize all foodzone surfaces of the ice machine and bin. Use a cloth or sponge to liberally apply the solution. When sanitizing, pay particular attention to the following areas:

- Evaporator plastic parts - including top, bottom and sides
- Bin bottom, sides and top

Do not rinse the sanitized areas.

Step 20 Replace all removed components.

Step 21 Reapply power and water to the ice machine and place the toggle switch in the ICE position.

Removal from Service/Winterization

General

Special precautions must be taken if the ice machine is to be removed from service for an extended period of time or exposed to ambient temperatures of 32°F (0°C) or below.

Caution

If water is allowed to remain in the ice machine in freezing temperatures, severe damage to some components could result. Damage of this nature is not covered by the warranty.

Follow the applicable procedure below.

Self-contained Air-cooled Models

1. Disconnect the electric power at the circuit breaker or the electric service switch.
2. Turn off the water supply.
3. Remove the water from the water trough.
4. Disconnect and drain the incoming ice-making water line at the rear of the ice machine.
5. Blow compressed air in both the incoming water and the drain openings in the rear of the ice machine until no more water comes out of the inlet water lines or the drain.
6. Make sure water is not trapped in any of the water lines, drain lines, distribution tubes, etc.

Water-cooled Ice Machines

1. Perform steps 1-6 under “Self-contained Air-cooled Models” on page 42.
2. Disconnect the incoming water and drain lines from the water-cooled condenser.
3. Insert a large screwdriver between the bottom spring coils of the water regulating valve. Pry upward to open the valve.

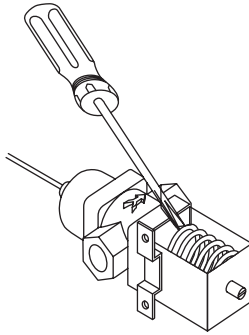

SV1624

Pry Open the Water Regulating Valve

4. Hold the valve open and blow compressed air through the condenser until no water remains.

THIS PAGE INTENTIONALLY LEFT BLANK

Operation

INITIAL START-UP OR START-UP AFTER AUTOMATIC SHUT-OFF

1. Pressure Equalization

Before the compressor starts the harvest valve is energized for 15 seconds to equalize pressures during the initial refrigeration system start-up.

2. Refrigeration System Start-up

The compressor starts after the 15-second pressure equalization, and remains on throughout the entire Freeze and Harvest Sequences. The harvest valve remains on for 5 seconds during initial compressor start-up and then shuts off.

At the same time the compressor starts, the condenser fan motor (air-cooled models) is supplied with power throughout the entire Freeze and Harvest Sequences. The fan motor is wired through a fan cycle pressure control, therefore it may cycle on and off. (The compressor and condenser fan motor are wired through the relay. As a result, any time the relay coil is energized, the compressor and fan motor are supplied with power.)

FREEZE SEQUENCE

3. Prechill

The compressor is on for 30 seconds prior to water flow to prechill the evaporator.

4. Freeze

The water pump starts after the 30-second prechill. An even flow of water is directed across the evaporator and into each cube cell, where it freezes.

When sufficient ice has formed, the water flow (not the ice) contacts the ice thickness probe. After approximately 7 seconds of continual water contact, the Harvest Sequence is initiated. The ice machine cannot initiate a Harvest Sequence until a 6-minute freeze time has been surpassed.

HARVEST SEQUENCE

5. Harvest

The water pump de-energizes stopping flow over the evaporator. The rising level of water in the sump trough diverts water out of the overflow tube, purging excess minerals from the sump trough. The harvest valve also opens to divert hot refrigerant gas into the evaporator.

The refrigerant gas warms the evaporator causing the cubes to slide, as a sheet, off the evaporator and into the storage bin. The sliding sheet of cubes contacts the ice damper, opening the bin switch.

The momentary opening and re-closing of the bin switch terminates the Harvest Sequence and returns the ice machine to the Freeze Sequence (steps 3 - 4).

AUTOMATIC SHUT-OFF

6. Automatic Shut-off

When the storage bin is full at the end of a harvest sequence, the sheet of cubes fails to clear the ice damper and will hold it down. After the ice damper is held open for 7 seconds, the ice machine shuts off. The ice machine remains off for 3 minutes before it can automatically restart.

The ice machine remains off until enough ice has been removed from the storage bin to allow the ice to fall clear of the damper. As the ice damper swings back to the operating position, the bin switch re-closes and the ice machine restarts (steps 1 - 2), provided the 3 minute delay period is complete.

ENERGIZED PARTS CHART

ICE MAKING SEQUENCE OF OPERATION	Control Board Relays			Relay		Length of Time
	1 Water Pump	2 Harvest Valve	3 Relay Coil	3A Compressor	3B Compressor Fan Motor*	
Initial Start-up 1. Water purge	off	on	off	off	off	15 seconds
	off	on	on	on	on	5 seconds
Freeze Sequence 3. Pre chill	off	off	on	on	on	30 seconds
	on	off	on	on	on	Until 7 sec. Water contact w/ice thickness probe
4. Freeze						

* Condenser Fan Motor: The fan motor is wired through a fan cycle pressure control; therefore, it may cycle on and off.

ICE MAKING SEQUENCE OF OPERATION	Control Board Relays			Relay		Length of Time
	1 Water Pump	2 Harvest Valve	3 Relay Coil	3A Compressor	3B Compressor Fan Motor*	
Harvest Sequence 5. Harvest	off	on	on	on	on	Bin switch activation
Automatic Shut-off 6. Auto Shut-off	off	off	off	off	off	Until bin switch re-closes

Operational Checks

Siphon System

To reduce mineral build-up and cleaning frequency, the water in the sump trough must be purged during each harvest cycle.

When the water pump de-energizes, the level in the water trough rises above the standpipe, starting a siphon action. The siphon action stops when the water level in the sump trough drops. When the siphon action stops, the float valve refills the water trough to the correct level.

Follow steps 1 through 6 under water level check to verify the siphon system functions correctly.

Water Level

Check the water level while the ice machine is in the ice mode and the water pump is running. The correct water level is 1/4" (6.3 mm) to 3/8" (9.5 mm) below the top of the standpipe. A line in the water trough indicates the correct level.

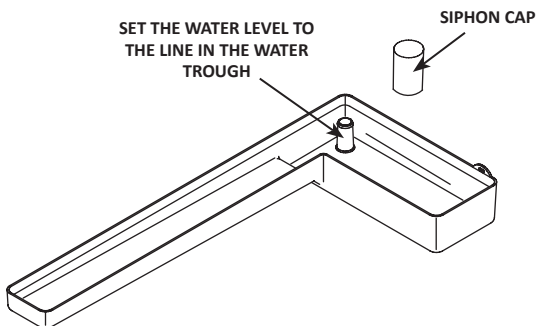

SV1689-1

Water Level Check

The float valve is factory-set for the proper water level. If adjustments are necessary:

1. Verify the ice machine is level.
2. Remove the siphon cap from the standpipe.
3. Place the main ON/OFF/WASH toggle switch to the ON position, and wait until the float valve stops adding water.
4. Adjust the water level to [1/4" to 3/8" (6.3 to 9.5 mm) below the standpipe] the line in the water trough:
 - A. Loosen the two screws on the float valve bracket.
 - B. Raise or lower the float valve assembly as necessary, then tighten the screws.
5. Move the main ON/OFF/WASH toggle switch to the OFF position. The water level in the trough will rise above the standpipe and run down the drain.
6. Replace the siphon cap on the standpipe, and verify water level and siphon action by repeating steps 3 through 5.

Ice Thickness Check

After a harvest cycle, inspect the ice cubes in the ice storage bin. The ice thickness probe is set to maintain an ice bridge of 1/8" (3.2 mm). If an adjustment is needed, follow the steps below.

1. Turn the ice thickness probe adjustment screw clockwise for a thicker ice bridge, or counterclockwise for a thinner ice bridge.
2. Make sure the ice thickness probe wire and bracket does not restrict movement of the probe.

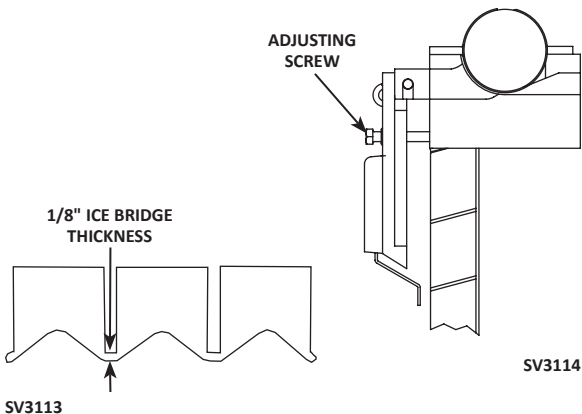

Ice Thickness Adjustment

THIS PAGE INTENTIONALLY LEFT BLANK

Troubleshooting

DIAGNOSING AN ICE MACHINE THAT WILL NOT RUN

Warning

High (line) voltage is applied to the control board (terminals #2 and #4) at all times. Removing control board fuse or moving the toggle switch to OFF will not remove the power supplied to the control board.

1. Verify primary voltage is supplied to ice machine and the fuse/circuit breaker is closed.
2. Verify control board fuse is okay.
3. If the bin switch light functions, the fuse is okay.
4. Verify the bin switch functions properly. A defective bin switch can falsely indicate a full bin of ice.
5. Verify ON/OFF/WASH toggle switch functions properly. A defective toggle switch may keep the ice machine in the OFF mode.
6. Verify low DC voltage is properly grounded. Loose DC wire connections may intermittently stop the ice machine.
7. Replace the control board.
8. Be sure Steps 1 – 5 were followed thoroughly. Intermittent problems are not usually related to the control board.

DIAGNOSING ICE THICKNESS CONTROL CIRCUITRY

Ice Machine Does Not Cycle Into Harvest when Water Contacts the Ice Thickness Control Probe

Step 1 Bypass the freeze time lock-in feature by moving the ON/OFF/WASH switch to OFF and back to ON. Wait until the water starts to flow over the evaporator.

Step 2 Clip the jumper wire to the ice thickness probe and any cabinet ground.

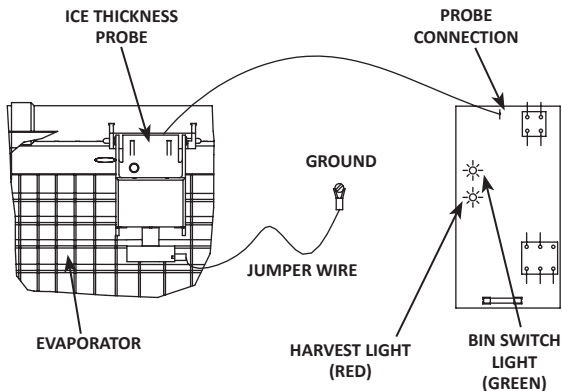

SV1592i

Step 2 Jumper wire connected from probe to ground	
Monitoring Harvest Light	Correction
The harvest light comes on, and 6-10 seconds later, ice machine cycles from freeze to harvest.	The ice thickness control circuitry is functioning properly. Do not change any parts.
The harvest light comes on but the ice machine stays in the freeze sequence.	The ice control circuitry is functioning properly. The ice machine is in a six minute freeze time lock-in. Verify Step 1 of this procedure was followed correctly.
The harvest light does not come on.	Proceed to Step 3.

Step 3 Disconnect the ice thickness probe from the control board terminal. Clip the jumper wire to the terminal on the control board and any cabinet ground. Monitor the harvest light.

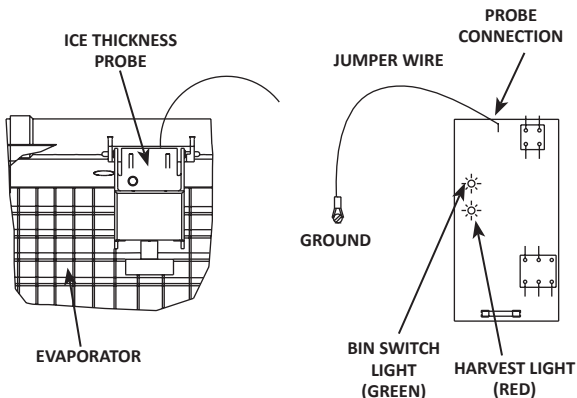

SV1592J

Step 3 Jumper wire connected from control board terminal to ground	
Monitoring Harvest Light	Correction
The harvest light comes on, and 6-10 seconds later, ice machine cycles from freeze to harvest.	The ice thickness probe is causing the malfunction.
The harvest light comes on but the ice machine stays in the freeze sequence.	The control circuitry is functioning properly. The ice machine is in a six-minute freeze time lock-in (verify step 1 of this procedure was followed correctly).
The harvest light does not come on.	The control board is causing the malfunction.

Ice Machine Cycles Into Harvest Before Water Contact with the Ice Thickness Probe

Step 1 Bypass the freeze time lock-in feature by moving the ON/OFF/WASH switch to OFF and back to ON. Wait until the water starts to flow over the evaporator, then monitor the harvest light.

Step 2 Disconnect the ice thickness probe from the control board terminal.

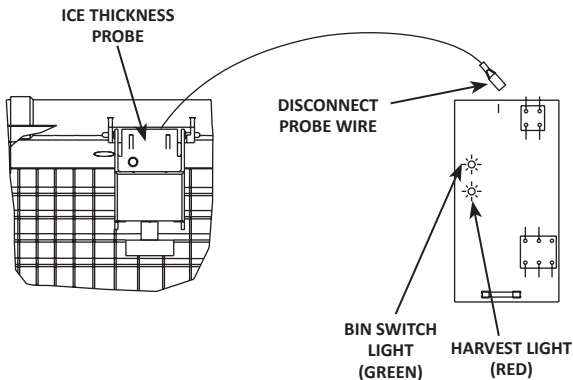

SV1592J_2

Step 2 Disconnect probe from control board terminal.	
Monitoring Harvest Light	Correction
The harvest light stays off and the ice machine remains in the freeze sequence.	The ice thickness probe is causing the malfunction. Verify that the ice thickness probe is adjusted correctly.
The harvest light comes on, and 6-10 seconds later, the ice machine cycles from freeze to harvest.	The control board is causing the malfunction.

ICE PRODUCTION CHECK

The amount of ice a machine produces directly relates to the operating water and air temperatures. This means an ice machine with a 70°F (21.2°C) ambient temperature and 50°F (10.0°C) water produces more ice than the same ice machine with 90°F (32.2°C) ambient and 70°F (21.2°C) water.

- Determine the ice machine operating conditions:

Air temp entering condenser: _____°

Air temp around ice machine: _____°

Water temp entering sump trough: _____°

- Refer to the appropriate 24-Hour Ice Production Chart. Use the operating conditions determined in step 1 to find published 24-Hour Ice Production: _____

- Times are in minutes.

Example: 1 min. 15 sec. converts to 1.25 min.
(15 seconds ÷ 60 seconds = .25 minutes)

- Weights are in pounds.

Example: 2 lb. 6 oz. converts to 2.375 lb.
(6 oz. ÷ 16 oz. = .375 lb.)

- Perform an ice production check using the formula below.

1.	_____	+	_____	=	_____
	Freeze Time		Harvest Time		Total Cycle Time
2.	$\frac{1440}{\text{_____}}$	÷	$\frac{\text{_____}}{\text{_____}}$	=	$\frac{\text{_____}}{\text{_____}}$
	Minutes in 24 Hrs.		Total Cycle Time		Cycles per Day
3.	$\frac{\text{_____}}{\text{_____}}$	×	$\frac{\text{_____}}{\text{_____}}$	=	$\frac{\text{_____}}{\text{_____}}$
	Weight of One Harvest		Cycles per Day		Actual 24-Hour Production

Weighing the ice is the only 100% accurate check. However, if the ice pattern is normal and the 1/8" (.44 cm) thickness is maintained, the ice slab weights listed with the 24-Hour Ice Production Charts may be used.

4. Compare the results of step 3 with step 2. Ice production is normal when these numbers match closely. If they match closely, determine if:
 - Another larger ice machine is required.
 - Relocating the existing equipment to lower the load conditions is required.

Contact the local distributor for information on available options and accessories.

INSTALLATION AND VISUAL INSPECTION CHECKLIST

Ice machine is not level

Level the ice machine

Condenser is dirty

- Clean the condenser

Water filtration is plugged (if used)

- Install a new water filter

Water drains are not run separately and/or are not vented

- Run and vent drains according to the Installation Manual

WATER SYSTEM CHECKLIST

A water-related problem often causes the same symptoms as a refrigeration system component malfunction.

Example: A water dump valve leaking during the freeze cycle, a system low on charge, and a starving TXV have similar symptoms.

Water system problems must be identified and eliminated prior to replacing refrigeration components.

Water area (evaporator) is dirty

- Clean as needed

Water inlet pressure not between 20 and 80 psig (1–5 bar, 138–552 kPa)

- Install a water regulator valve or increase the water pressure

Incoming water temperature is not between 35°F (1.7°C) and 90°F (32.2°C)

- If too hot, check the hot water line check valves in other store equipment

Water filtration is plugged (if used)

- Install a new water filter

Vent tube is not installed on water outlet drain

- See Installation Instructions

Hoses, fittings, etc., are leaking water

- Repair/replace as needed

Water float valve is stuck open or closed

- Clean/replace as needed

Water is spraying out of the sump trough area

- Stop the water spray

Uneven water flow across the evaporator

- Clean the ice machine

Water is freezing behind the evaporator

- Correct the water flow

Plastic extrusions and gaskets are not secured to the evaporator

- Remount/replace as needed

Extremely Thin at Evaporator Outlet

There is no ice, or a considerable lack of ice formation on the outlet of the evaporator.

Examples: No ice at all at the outlet of the evaporator, but ice forms at the inlet half of the evaporator. Or, the ice at the outlet of the evaporator reaches the correct thickness, but the outlet of the evaporator already has 1/2" to 1" of ice formation.

Possible cause: Water loss, low on refrigerant, starving TXV, hot water supply, faulty float valve, etc.

Extremely Thin at Evaporator Inlet

There is no ice, or a considerable lack of ice formation at the inlet of the evaporator. Examples: The ice at the outlet of the evaporator reaches the correct thickness, but there is no ice formation at all at the inlet of the evaporator.

Possible cause: Insufficient water flow, flooding TXV, etc.

Spotty Ice Formation

There are small sections on the evaporator where there is no ice formation. This could be a single corner, or a single spot in the middle of the evaporator. This is generally caused by loss of heat transfer from the tubing on the backside of the evaporator.

No Ice Formation

The ice machine operates for an extended period, but there is no ice formation at all on the evaporator.

Possible cause: Water float valve, water pump, starving expansion valve, low refrigerant charge, compressor, etc.

SAFETY LIMIT FEATURE

In addition to the standard safety controls, your Koolaire® ice machine features built-in safety limits that will stop the ice machine if conditions arise which could cause a major component failure.

Before calling for service, re-start the ice machine using the following procedure:

1. Move the ON/OFF/WASH switch to OFF and then back to ON.
2. If the safety limit feature has stopped the ice machine, it will restart after a short delay. Proceed to step 4.
3. If the ice machine does not restart, see “Ice machine does not operate”.
4. Allow the ice machine to run to determine if the condition is reoccurring.
 - A. If the ice machine stops again, the condition has reoccurred. Call for service.
 - B. If the ice machine continues to run, the condition has corrected itself. Allow the ice machine to continue running.

Safety Limits

In addition to standard safety controls, the control board has two built in safety limit controls which protect the ice machine from major component failures.

Safety Limit #1: If the freeze time reaches 60 minutes, the control board automatically initiates a harvest cycle. 3 cycles outside the time limit = 1 hour Stand-by Mode.

Safety Limit #2: If the harvest time reaches 3.5 minutes, the control board automatically returns the ice machine to the freeze cycle. 3 cycles outside the time limit = Safety Limit (must be MANUALLY reset).

Safety Limit Stand-by Mode: The first time a safety limit shut down occurs, the ice machine turns off for 60 minutes (Stand-by Mode). The ice machine will then automatically restart to see if the problem reoccurs. During the Stand-by Mode the harvest light will be flashing continuously and a safety limit indication can be viewed. If the same safety limit is reached a second time (the problem has reoccurred), the ice machine will initiate a safety limit shut down and remain off until it is manually restarted. During a safety limit shut down the harvest light will be flashing continuously.

Determining Which Safety Limit Stopped the Ice Machine: When a safety limit condition causes the ice machine to stop, the harvest light on the control board continually flashes on and off. Use the following procedures to determine which safety limit has stopped the ice machine.

1. Move the toggle switch to OFF.
2. Move the toggle switch back to ON.
3. Watch the harvest light. It will flash one or two times, corresponding to safety limits 1 and 2, to indicate which safety limit stopped the ice machine.

After safety limit indication, the ice machine will restart and run until a safety limit is exceeded again.

Safety Limit Notes

- A safety limit indication is completed before the water pump starts. Water contacting the ice thickness probe in the freeze cycle will cause the harvest light to flash. Do not mistake a harvest light flashing in the freeze cycle with a safety limit indication.
- A continuous run of 100 harvests automatically erases the safety limit code.
- The control board will store and indicate only one safety limit – the last one exceeded.
- If the toggle switch is moved to the OFF position and then back to the ON position prior to reaching the 100-harvest point, the last safety limit exceeded will be indicated.
- If the harvest light did not flash prior to the ice machine restarting, then the ice machine did not stop because it exceeded a safety limit.

ANALYZING WHY SAFETY LIMITS MAY STOP THE ICE MACHINE

According to the refrigeration industry, a high percentage of compressor failure is a result of external causes. These can include flooding or starving expansion valves, dirty condensers, water loss to the ice machine, etc. The safety limits protect the ice machine (primarily the compressor) from external failures by stopping ice machine operation before major component damage occurs.

The safety limit system is similar to a high-pressure cutout control. It stops the ice machine, but does not tell what is wrong. The service technician must analyze the system to determine what caused the high-pressure cutout, or a particular safety limit, to stop the ice machine.

The safety limits are designed to stop the ice machine prior to major component failures, most often a minor problem or something external to the ice machine. This may be difficult to diagnose, as many external problems occur intermittently.

Example: An ice machine stops intermittently on safety limit #1 (long freeze times). The problem could be a low ambient temperature at night, a water pressure drop; the water is turned off one night a week, etc.

When a high-pressure cutout or a safety limit stops the ice machine, they are doing what they are supposed to do. That is, stopping the ice machine before a major component failure occurs.

Refrigeration and electrical component failures may also trip a safety limit. Eliminate all electrical components and external causes first. If it appears that the refrigeration system is causing the problem, use the Refrigeration System Operational Analysis Table, along with detailed charts, checklists, and other references to determine the cause.

Safety Limit Checklist

The following checklists are designed to assist the service technician in analysis. However, because there are many possible external problems, do not limit your diagnosis to only the items listed.

Safety Limit #1

Freeze time exceeds 60 minutes for 6 consecutive freeze cycles.

Possible Cause Checklist

Improper Installation

- Refer to "Installation and Visual Inspection Checklist" on page 59

Water System

- Water Level set too high (water escaping through over flow tube)
- Low water pressure (20 psig min.)
- High water pressure (80 psig max.)
- High water temperature (90°F/32.2°C max.)
- Clogged water distribution tube
- Dirty/defective float valve
- Defective water pump

Electrical System

- Ice thickness probe out of adjustment
- Harvest cycle not initiated electrically
- Compressor relay not energizing
- Compressor electrically non-operational
- High inlet air temperature (110°F/43.3°C max.)
- Defective fan cycling control
- Defective fan motor
- Dirty condenser

Refrigeration System

- Restricted condenser air flow
- Condenser discharge air re-circulation
- Dirty condenser fins
- Non-OEM components
- Improper refrigerant charge
- Defective compressor
- TXV starving or flooding (check bulb mounting)
- Non-condensable in refrigeration system
- Plugged or restricted high side refrigerant lines or component
- Defective harvest valve

Safety Limit #2

Harvest time exceeds 3.5 minutes for 6 Consecutive harvest cycles.

Possible Cause Checklist

Improper Installation

- Refer to “Installation and Visual Inspection Checklist” on page 59.

Water System

- Water area (evaporator) dirty
- Dirty/defective water dump valve
- Vent tube not installed on water outlet drain
- Water freezing behind evaporator
- Plastic extrusions and gaskets not securely mounted to the evaporator
- Low water pressure (20 psig min.)
- Loss of water from sump area
- Clogged water distribution tube
- Dirty/defective float valve
- Defective water pump

Electrical System

- Ice thickness probe out of adjustment
- Ice thickness probe dirty
- Bin switch defective
- Premature harvest

Refrigeration System

- Non-OEM components
- Improper refrigerant charge
- Defective harvest valve
- TXV flooding (check bulb mounting)
- Defective fan cycling control

ANALYZING DISCHARGE PRESSURE

1. Determine the ice machine operating conditions:

Air temp. entering condenser _____

Air temp. around ice machine _____

Water temp. entering sump trough _____

2. Refer to "Cycle Times, 24 Hr. Ice Production and Refrigerant Pressure Charts" on page 123 for ice machine being checked.

Use the operating conditions determined in step 1 to find the published normal discharge pressures.

Freeze Cycle _____

Harvest Cycle _____

3. Perform an actual discharge pressure check.

	Freeze Cycle PSIG	Harvest Cycle PSIG
Beginning of Cycle	_____	_____
Middle of Cycle	_____	_____
End of Cycle	_____	_____

4. Compare the actual discharge pressure (step 3) with the published discharge pressure (step 2).

The discharge pressure is normal when the actual pressure falls within the published pressure range for the ice machine's operating conditions. It is normal for the discharge pressure to be higher at the beginning of the freeze cycle (when load is greatest), then drop through out the freeze cycle.

Discharge Pressure High Checklist

Improper Installation

- Refer to “Installation and Visual Inspection Checklist” on page 59.

Restricted Condenser Air Flow

- High inlet air temperature
- Condenser discharge air re-circulation
- Dirty condenser fins
- Defective fan cycling control
- Defective fan motor

Improper Refrigerant Charge

- Overcharged
- Non-condensable in system
- Wrong type of refrigerant

Other

- Non-OEM components in system
- High side refrigerant lines/component
- Restricted (before mid-condenser)

Freeze Cycle Discharge Pressure Low Checklist

Improper Installation

- Refer to “Installation and Visual Inspection Checklist” on page 59.

Improper Refrigerant Charge

- Undercharged
- Wrong type of refrigerant

Other

- Non-OEM components in system
- High side refrigerant lines/component restricted (before mid-condenser)
- Defective fan cycle control

NOTE: Do not limit your diagnosis to only the items listed in the checklists.

ANALYZING SUCTION PRESSURE

The suction pressure gradually drops throughout the freeze cycle. The actual suction pressure (and drop rate) changes as the air and water temperature entering the ice machine changes. These variables also determine the freeze cycle times.

To analyze and identify the proper suction pressure drop throughout the freeze cycle, compare the published suction pressure to the published freeze cycle time.

NOTE: Analyze discharge pressure before analyzing suction pressure. High or low discharge pressure may be causing high or low suction pressure.

Procedure

Step																					
<p>1. Determine the ice machine operating conditions.</p> <p><i>Example:</i></p> <p><i>Air temp. entering condenser: 90°F/32.2°C</i></p> <p><i>Air temp. around ice machine: 80°F/26.7°C</i></p> <p><i>Water temp. entering water fill valve: 70°F/21.1°C</i></p>																					
<p>2A. Refer to “Cycle Time” and “Operating Pressure” charts for ice machine model being checked. Using operating conditions from Step 1, determine published freeze cycle time and published freeze cycle suction pressure.</p> <p><i>Example:</i></p> <p><i>Published freeze cycle time: 14.8 - 15.9 minutes</i></p> <p><i>Published freeze cycle suction pressure: 65 - 26 psig</i></p>																					
<p>2B. Compare the published freeze cycle time and published freeze cycle suction pressure. Develop a chart.</p> <p><i>Example:</i></p> <p><u><i>Published Freeze Cycle Time (minutes)</i></u></p> <table style="margin-left: auto; margin-right: auto;"> <tr> <td style="text-align: center;">1</td> <td style="text-align: center;">2</td> <td style="text-align: center;">4</td> <td style="text-align: center;">7</td> <td style="text-align: center;">10</td> <td style="text-align: center;">12</td> <td style="text-align: center;">14</td> </tr> <tr> <td style="text-align: center;"> </td> <td style="text-align: center;"> </td> <td style="text-align: center;"> </td> <td style="text-align: center;"> </td> <td style="text-align: center;"> </td> <td style="text-align: center;"> </td> <td style="text-align: center;"> </td> </tr> <tr> <td style="text-align: center;">65</td> <td style="text-align: center;">55</td> <td style="text-align: center;">47</td> <td style="text-align: center;">39</td> <td style="text-align: center;">34</td> <td style="text-align: center;">30</td> <td style="text-align: center;">26</td> </tr> </table> <p><u><i>Published Freeze Cycle Suction Pressure (psig)</i></u></p> <p><i>In the example, the proper suction pressure should be approximately 39 psig at 7 minutes; 30 psig at 12 minutes; etc.</i></p>	1	2	4	7	10	12	14								65	55	47	39	34	30	26
1	2	4	7	10	12	14															
65	55	47	39	34	30	26															
<p>3. Perform an actual suction pressure check at the beginning, middle and end of the freeze cycle. Note the times at which the readings are taken.</p> <p><i>Example:</i></p> <p><i>Manifold gauge set was connected to the example ice machine and suction pressure readings taken as follows: _____ PSIG</i></p> <p><i>Beginning of freeze cycle: 79 (at 1 min.)</i></p> <p><i>Middle of freeze cycle: 48 (at 7 min.)</i></p> <p><i>End of freeze cycle: 40 (at 14 min.)</i></p>																					
<p>4. Compare the actual freeze cycle suction pressure (Step 3) to the published freeze cycle time and pressure comparison (Step 2B). Determine if the suction pressure is high, low or acceptable.</p> <p><i>Example:</i></p> <p><i>In this example, the suction pressure is considered high throughout the freeze cycle. It should have been:</i></p> <p><i>Approximately 65 psig (at 1 minute) – not 79</i></p> <p><i>Approximately 39 psig (at 7 minutes) – not 48</i></p> <p><i>Approximately 26 psig (at 14 minutes) – not 40</i></p>																					

Suction Pressure High Checklist

Improper Installation

- Refer to “Installation and Visual Inspection Checklist” on page 59.

Discharge Pressure

- Discharge pressure is too high, and is affecting suction pressure, refer to “Discharge Pressure High Checklist” on page 71.

Improper Refrigerant Charge

- Overcharged
- Wrong type of refrigerant
- Non-condensable in system

Other

- Non-OEM components in system
- Harvest valve leaking
- TXV flooding (check bulb mounting)
- Defective compressor

Suction Pressure Low Checklist

Improper Installation

- Refer to “Installation and Visual Inspection Checklist” on page 59.

Discharge Pressure

- Discharge pressure is too low, and is affecting suction pressure, refer to “Freeze Cycle Discharge Pressure Low Checklist”

Improper Refrigerant Charge

- Undercharged
- Wrong type of refrigerant

Other

- Non-OEM components in system
- Improper water supply over evaporator refer to “Water System Checklist” on page 60.
- Loss of heat transfer from tubing on back side of evaporator
- Restricted/plugged liquid line drier
- Restricted/plugged tubing in suction side of refrigeration system
- TXV starving

NOTE: Do not limit your diagnosis to only the items listed in the checklists.

HARVEST VALVE

General

The harvest valve is an electrically operated valve that opens when energized, and closes when de-energized.

Normal Operation

The valve is de-energized (closed) during the freeze cycle and energized (open) during the harvest cycle. The valve is positioned between the receiver and the evaporator and performs two functions:

1. Prevents refrigerant from entering the evaporator during the freeze cycle.

The harvest valve is not used during the freeze cycle. The harvest valve is de-energized (closed) preventing refrigerant flow from the receiver into the evaporator.

2. Allows refrigerant vapor to enter the evaporator in the harvest cycle.

During the harvest cycle, the harvest valve is energized (open) allowing refrigerant gas from the discharge line of the compressor to flow into the evaporator. The heat is absorbed by the evaporator and allows release of the ice slab.

Exact pressures vary according to ambient temperature and ice machine model. Harvest pressures can be found in the Cycle Time/24 Hour Ice Production/Refrigerant Pressure Charts in this book.

Harvest Valve Analysis

The valve can fail in two positions:

- Valve will not open in the harvest cycle.
- Valve remains open during the freeze cycle.

VALVE WILL NOT OPEN IN THE HARVEST CYCLE

Although the circuit board has initiated a harvest cycle, the evaporator temperature remains unchanged from the freeze cycle.

Caution

Coil must be seated 100% on solenoid to function correctly. Install coil with a twisting motion to properly seat.

VALVE REMAINS OPEN IN THE FREEZE CYCLE:

Symptoms of a harvest valve remaining partially open during the freeze cycle can be similar to symptoms of an expansion valve, float valve or compressor problem. Symptoms are dependent on the amount of leakage in the freeze cycle.

A small amount of leakage will cause increased freeze times and an ice fill pattern that is “Thin at the Outlet”, but fills in at the end of the cycle.

As the amount of leakage increases the length of the freeze cycle increases and the amount of ice at the outlet of the evaporator decreases.

Refer to the Parts Manual for proper valve application. If replacement is necessary, use only “original” replacement parts.

Use the following procedure and table to help determine if a harvest valve is remaining partially open during the freeze cycle.

1. Wait five minutes into the freeze cycle.
2. Feel the inlet of the harvest valve.

Important

Feeling the harvest valve outlet or across the harvest valve itself will not work for this comparison.

The harvest valve outlet is on the suction side (cool refrigerant). It may be cool enough to touch even if the valve is leaking.

3. Feel the compressor discharge line.

Warning

The inlet of the harvest valve and the compressor discharge line could be hot enough to burn your hand. Just touch them momentarily.

4. Compare the temperature of the inlet of the harvest valve to the temperature of the compressor discharge line.

Findings	Comments
<p>The inlet of the harvest valve is cool enough to touch and the compressor discharge line is hot.</p> <p style="text-align: center;">Cool & Hot</p>	<p>This is normal as the discharge line should always be too hot to touch and the harvest valve inlet, although too hot to touch during harvest, should be cool enough to touch after 5 minutes into the freeze cycle.</p>
<p>The inlet of the harvest valve is hot and approaches the temperature of a hot compressor discharge line.</p> <p style="text-align: center;">Hot & Hot</p>	<p>This is an indication something is wrong, as the harvest valve inlet did not cool down during the freeze cycle. If the compressor dome is also entirely hot, the problem is not a harvest valve leaking, but rather something causing the compressor (and the entire ice machine) to get hot.</p>
<p>Both the inlet of the harvest valve and the compressor discharge line are cool enough to touch.</p> <p style="text-align: center;">Cool & Cool</p>	<p>This is an indication something is wrong, causing the compressor discharge line to be cool to the touch. This is not caused by a harvest valve leaking.</p>

5. Record your findings on the table.

COMPARING EVAPORATOR INLET/OUTLET TEMPERATURES

The temperatures of the suction lines entering and leaving the evaporator alone cannot diagnose an ice machine. However, comparing these temperatures during the freeze cycle, along with using the Refrigeration System Operational Analysis Table, can help diagnose an ice machine malfunction.

The actual temperatures entering and leaving the evaporator vary by model, and change throughout the freeze cycle. This makes documenting the “normal” inlet and outlet temperature readings difficult. The key to the diagnosis lies in the difference between the two temperatures five minutes into the freeze cycle. These temperatures must be within 7°F (4°C) of each other.

Use this procedure to document freeze cycle inlet and outlet temperatures.

1. Use a quality temperature meter, capable of taking temperature readings on curved copper lines.
2. Attach the temperature meter sensing device to the copper lines entering and leaving the evaporator.

Important

Do not simply insert the sensing device under the insulation. It must be attached to and reading the actual temperature of the copper line.

3. Wait five minutes into the freeze cycle.
4. Record the temperatures below and determine the difference between them.

_____	_____	_____
Inlet Temperature	Difference must be within 7°F (4°C) at 5 minutes into the freeze cycle	Outlet Temperature

5. Use this with other information gathered on the Refrigeration System Operational Analysis Table to determine the ice machine malfunction.

DISCHARGE LINE TEMPERATURE ANALYSIS

GENERAL

Knowing if the discharge line temperature is increasing, decreasing or remaining constant can be an important diagnostic tool. Maximum compressor discharge line temperature on a normally operating ice machine steadily increases throughout the freeze cycle. Comparing the temperatures over several cycles will result in a consistent maximum discharge line temperature.

Ambient air temperatures affect the maximum discharge line temperature.

Higher ambient air temperatures at the condenser = higher discharge line temperatures at the compressor.

Lower ambient air temperatures at the condenser = lower discharge line temperatures at the compressor.

Regardless of ambient temperature, the freeze cycle discharge line temperature will be higher than 150°F (66°C) on a normally operating ice machine.

PROCEDURE

Connect a temperature probe on the compressor discharge line within 6" (15.2 cm) of the compressor.

Observe the discharge line temperature for the last three minutes of the freeze cycle and record the maximum discharge line temperature.

Discharge Line Temperature Above 150°F (66°C) at End of Freeze Cycle:

Ice machines that are operating normally will have consistent maximum discharge line temperatures above 150°F (66°C).

Verify the expansion valve sensing bulb is positioned and secured correctly.

Discharge Line Temperature Below 150°F (66°C) at End of Freeze Cycle

Ice machines that have a flooding expansion valve will have a maximum discharge line temperature that decreases each cycle.

Verify the expansion valve sensing bulb is 100% insulated and sealed airtight. Condenser air contacting an incorrectly insulated sensing bulb will cause overfeeding of the expansion valve.

REFRIGERATION COMPONENT DIAGNOSTIC CHART

All electrical and water related problems must be corrected before these charts will work properly. These tables must be used with charts, checklists and other references to eliminate refrigeration components not listed and external items and problems that will cause good refrigeration components to appear defective.

The tables list four different defects that may affect the ice machine's operation.

NOTE: A low-on-charge ice machine and a starving expansion valve have very similar characteristics and are listed under the same column.

PROCEDURE

Step 1 Complete each item individually in the “Operational Analysis” column.

Enter check marks (✓) in the boxes.

Each time the actual findings of an item in the “Operational Analysis” column matches the published findings on the table, enter a check mark.

Example: Freeze cycle suction pressure is determined to be low. Enter a check mark in the “low” box.

Perform the procedures and check all information listed. Each item in this column has supporting reference material.

While analyzing each item separately, you may find an “external problem” causing a good refrigerant component to appear bad. **Correct problems as they are found. If the operational problem is found, it is not necessary to complete the remaining procedures.**

Step 2 Add the check marks listed under each of the four columns. Note the column number with the highest total and proceed to “Final Analysis.”

NOTE: If two columns have matching high numbers, a procedure was not performed properly and/or supporting material was not analyzed correctly.

FINAL ANALYSIS

The column with the highest number of check marks identifies the refrigeration problem.

Column 1 – Harvest Valve Leaking

A leaking harvest valve must be replaced.

Column 2 – Low Charge/TXV Starving

Normally, a starving expansion valve only affects the freeze cycle pressures, not the harvest cycle pressures. A low refrigerant charge normally affects both pressures. Verify the ice machine is not low on charge before replacing an expansion valve.

Add refrigerant charge in 2 oz. increments as a diagnostic procedure to verify a low charge. (Do not add more than the total charge of refrigerant). If the problem is corrected, the ice machine is low on charge. Find the refrigerant leak.

The ice machine must operate with the nameplate charge. If the leak cannot be found, proper refrigerant procedures must still be followed. Change the liquid line drier, evacuate the system and weigh in the proper charge.

If the problem is not corrected by adding charge, the expansion valve is faulty.

Column 3 – TXV Flooding

A loose or improperly mounted expansion valve bulb causes the expansion valve to flood. Check bulb mounting, insulation, etc., before changing the valve.

Column 4 – Compressor

Replace the compressor and start components. To receive warranty credit, the compressor ports must be properly sealed by crimping and soldering them closed. Old start components must be returned with the faulty compressor.

REFRIGERATION COMPONENT DIAGNOSTIC CHART

	1	2	3	4
Operational Analysis				
Ice Production	<p>Published 24 hour ice production _____ Calculated (actual) 24 hour ice production _____</p> <p>NOTE: The ice machine is operating properly if the ice fill pattern is normal and ice production is within 10% of charted capacity.</p>			
Installation and Water System	<p>All installation and water related problems must be corrected before proceeding with chart.</p>			
Ice Formation Pattern	<p>Ice formation is extremely thin on top of evaporator -or- No ice formation on the entire evaporator</p>	<p>Ice formation extremely thin on top of the evaporator -or- No ice formation on entire evaporator</p>	<p>Ice formation is normal -or- Ice formation is extremely thin on the bottom of evaporator -or- no ice formation on evaporator</p>	<p>Ice formation is normal -or- No ice formation on entire evaporator</p>

Operational Analysis	1	2	3	4
Safety Limits Refer to "Analyzing Safety Limits" to eliminate all non-refrigeration problems.	Stops on safety limit: 1 or 2	Stops on safety limit: 1	Stops on safety limit: 1 or 2	Stops on safety limit: 1
Freeze Cycle Discharge Pressure 1 minute Middle End into cycle	If discharge pressure is High or Low, refer to freeze cycle high or low discharge pressure problem checklist to eliminate problems and/or components not listed on this table before proceeding.			
Freeze Cycle Suction Pressure 1 minute Middle End	If suction pressure is High or Low refer to freeze cycle high or low suction pressure problem checklist to eliminate problems and/or components not listed on this table before proceeding.			
	Suction pressure is High	Suction pressure is Low	Suction pressure is High	Suction pressure is High

Operational Analysis	1	2	3	4
Harvest Valve	The harvest valve inlet is HOT and the compressor discharge line is HOT	The harvest valve inlet is COOL and the compressor discharge line is HOT	The harvest valve inlet is COOL and the compressor discharge line is COOL	The harvest valve inlet is COOL and the compressor discharge line is HOT
Discharge Line Temp. Record freeze cycle discharge line temp at the end of freeze cycle.	Discharge line temp 150°F (66°C) or higher at the end of freeze cycle	Discharge line temp 150°F (66°C) or higher at the end of freeze cycle	Discharge line temp less than 150°F (66°C) at the end of freeze cycle	Discharge line temp 150°F (66°C) or higher at the end of freeze cycle
Final Analysis Enter total number of boxes checked in each column.	Harvest Valve Leaking	Low On Charge -or- TXV Starving	TXV Flooding	Compressor

ICE QUALITY IS POOR — CUBES ARE SHALLOW, INCOMPLETE OR WHITE

Ice machine is dirty

- Clean and sanitize the ice machine

Water filtration is poor

- Replace the filter

Water softener is working improperly (if applicable)

- Repair the water softener

Poor incoming water quality

- Contact a qualified company to test the quality of the incoming water and make appropriate filter recommendations

Water escaping from sump during freeze cycle

- Check standpipe and drain
- Check for water tracking out of water circuit

FREEZE CYCLE IS LONG, LOW ICE PRODUCTION

Water temperature is too high

- Connect to a cold water supply, verify check valves in faucets and other equipment are functioning correctly

Dirty Condenser

- Clean condenser

High air temperature entering condenser

- Air temperature must not exceed 120°F (39°C)

Water inlet valve filter screen is dirty

- Remove the water inlet valve and clean the filter screen

Water inlet valve stuck open or leaking

- Turn off ice machine, if water continues to enter ice machine, verify water pressure is ok then replace water inlet valve

Water inlet valve is not working

- Water inlet valve must be replaced

Refrigeration problem

- Refer to refrigeration diagnostics

Water escaping from sump during freeze cycle

- Check standpipe and drain
- Check for water tracking out of water circuit

ICE MACHINE RUNS AND NO ICE IS PRODUCED

No water to ice machine

- Correct water supply

Incorrect incoming water pressure

- Water pressure must be 20-80 psi (1.4-5.5 bar)

Excessive mineral buildup

- Clean and sanitize the ice machine

Ambient temperature is too high or low

- Ambient temperature must be between 50°F and 110°F (10°C and 43°C)

Compressor relay inoperable

- No voltage to coil or coil defective
- Defective contacts

Compressor off on overload

- Condenser fan motor defective
- Incorrect flow to water cooled condenser
- Ambient temperature too high
- Condenser blocked
- Faulty start components

THIS PAGE INTENTIONALLY LEFT BLANK

Component Check Procedures

Main Fuse

Function

The control board fuse stops ice machine operation if electrical components fail causing high amp draw.

Specifications

The main fuse is 250 Volt, 10 amp.

Warning

High (line) voltage is applied to the control board at all times. Removing the control board fuse or moving the toggle switch to OFF will not remove the power supplied to the control board.

Check Procedure

1. If the bin switch light is on with the ice damper closed, the fuse is good.

Warning

Disconnect electrical power to the entire ice machine before proceeding.

2. Remove the fuse. Check the resistance across the fuse with an ohmmeter.

Reading	Result
Open (OL)	Replace fuse
Closed (O)	Fuse is good

Bin Switch

Function

Bin switch operation is controlled by the movement of the ice damper. The bin switch has two main functions:

1. Terminating the harvest cycle and returning the ice machine to the freeze cycle.

This occurs when the bin switch is opened and closed again within 7 seconds of opening during the harvest cycle.

2. Automatic ice machine shut-off.

If the storage bin is full at the end of a harvest cycle, the sheet of cubes fails to clear the ice damper and holds it down. After the ice damper is held down for 7 seconds, the ice machine shuts off.

The ice machine remains off until enough ice is removed from the storage bin to allow the sheet of cubes to drop clear of the ice damper. As the ice damper swings back to the operating position, the bin switch closes and the ice machine restarts.

Important

The ice damper must be up (bin switch closed) to start ice making.

Check Procedure

1. Set the toggle switch to OFF.
2. Watch the bin switch light on the control board.
3. Move the ice damper upward, toward the evaporator. The bin switch must close. The bin switch light “on” indicates the bin switch has closed properly.
4. Move the ice damper away from the evaporator. The bin switch must open. The bin switch light “off” indicates the bin switch has opened properly.

Ohm Test

1. Disconnect the bin switch wires to isolate the bin switch from the control board.
2. Connect an ohmmeter to the disconnected bin switch wires.
3. Cycle the bin switch open and closed numerous times by opening and closing the water curtain.

NOTE: To prevent mis-diagnosis:

- Always use the water curtain magnet to cycle the switch (a larger or smaller magnet will affect switch operation).
- Watch for consistent readings when the bin switch is cycled open and closed (bin switch failure could be erratic).

Bin Switch Removal

1. Disconnect power to the ice machine at service disconnect.
2. Disconnect bin switch wires in control box.
3. Insert a small screwdriver through the hole located in the top of the bin switch, and depress mounting tab slightly.
4. While depressing mounting tab roll bin switch to right to release.
5. Pull wiring into evaporator compartment.

INSERT SCREWDRIVER
AND DEPRESS TAB

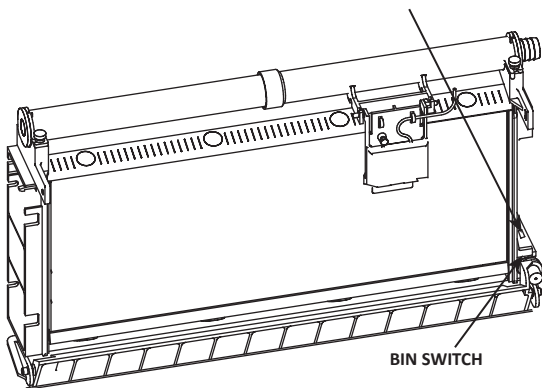

SV1695B

Bin Switch Removal

Diagnosing Start Components

If the compressor attempts to start, or hums and trips the overload protector, check the start components before replacing the compressor.

CAPACITOR

Visual evidence of capacitor failure can include a bulged terminal end or a ruptured membrane. Do not assume a capacitor is good if no visual evidence is present. A good test is to install a known good substitute capacitor. Use a capacitor tester when checking a suspect capacitor. Clip the bleed resistor off the capacitor terminals before testing.

RELAY

The relay has a set of contacts that connect and disconnect the start capacitor from the compressor start winding. The contacts on the relay are normally open. The relay senses the voltage generated by the start winding and closes and then opens the contacts as the compressor motor starts. The contacts remain open until the compressor is de-energized.

ON/OFF/WASH Toggle Switch

Function

The switch is used to place the ice machine in ON, OFF or WASH mode of operation.

Specifications

Single-pole, double-throw switch. The switch is connected into a varying low D.C. voltage circuit.

Check Procedure

NOTE: Because of a wide variation in D.C. voltage, it is not recommended that a voltmeter be used to check toggle switch operation.

1. Inspect the toggle switch for correct wiring.
2. Isolate the toggle switch by disconnecting all wires from the switch, or by disconnecting the Molex connector from the control board.
3. Check across the toggle switch terminals using a calibrated ohmmeter. Note where the wire numbers are connected to the switch terminals, or refer to the wiring diagram to take proper readings.

Switch Setting	Terminals	Ohm Reading
ON	24-21	Open
	24-20	Closed
	20-21	Open
WASH	24-20	Open
	24-21	Closed
	20-21	Open
OFF	24-20	Open
	24-21	Open
	20-21	Open

Replace the toggle switch if ohm readings do not match all three-switch settings.

Ice Thickness Probe

How the Probe Works

The Koolaire® electronic sensing circuit does not rely on refrigerant pressure, evaporator temperature, water levels or timers to produce consistent ice formation.

As ice forms on the evaporator, water (not ice) contacts the ice thickness probe. After the water completes this circuit across the probe continuously for 6-10 seconds, a harvest cycle is initiated.

Freeze Time Lock-In Feature

The ice machine control system incorporates a freeze time lock-in feature. This prevents the ice machine from short cycling in and out of harvest.

The control board locks the ice machine in the freeze cycle for six minutes. If water contacts the ice thickness probe during these six minutes, the harvest light will come on (to indicate that water is in contact with the probe), but the ice machine will stay in the freeze cycle. After the six minutes are up, a harvest cycle is initiated. This is important to remember when performing diagnostic procedures on the ice thickness control circuitry.

To allow the service technician to initiate a harvest cycle without delay, this feature is not used on the first cycle after moving the toggle switch OFF and back to ON.

Maximum Freeze Time

The control system includes a built-in safety, which will automatically cycle the ice machine into harvest after 60 minutes in the freeze cycle.

ICE THICKNESS CHECK

The ice thickness probe is factory-set to maintain the ice bridge thickness at 1/8" (3.2 mm).

NOTE: Make sure the water curtain is in place when performing this check. It prevents water from splashing out of the water trough.

1. Inspect the bridge connecting the cubes. It should be about 1/8" (3.2 mm) thick.
2. If adjustment is necessary, turn the ice thickness probe adjustment screw clockwise to increase bridge thickness, or counterclockwise to decrease bridge thickness.

NOTE: Turning the adjustment 1/3 of a turn will change the ice thickness about 1/16" (1.5 mm).

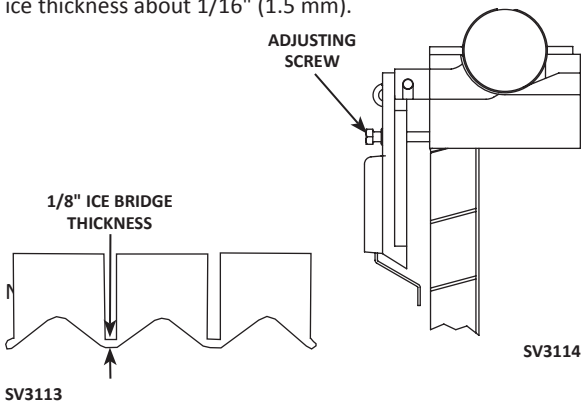

Ice Thickness Check

Make sure the ice thickness probe wire and the bracket do not restrict movement of the probe.

Compressor Electrical Diagnostics

The compressor does not start or will trip repeatedly on overload.

Check Resistance (Ohm) Values

NOTE: Compressor windings can have very low ohm values. Use a properly calibrated meter.

Perform the resistance test after the compressor cools. The compressor dome should be cool enough to touch (below 120°F/49°C) to ensure that the overload is closed and the resistance readings will be accurate.

Single Phase Compressors

1. Disconnect power from the condensing unit and remove the wires from the compressor terminals.
2. The resistance values between C and S and between C and R, when added together should equal the resistance value between S and R.
3. If the overload is open, there will be a resistance reading between S and R, and open readings between C and S and between C and R. Allow the compressor to cool, then check the readings again.

Check Motor Windings to Ground

Check continuity between all three terminals and the compressor shell or copper refrigeration line. Scrape metal surface to get good contact. If continuity is present, the compressor windings are grounded and the compressor should be replaced.

To determine if the compressor is seized check the amp draw while the compressor is trying to start.

Compressor Drawing Locked Rotor

The two likely causes of this are:

- Defective starting component
- Mechanically seized compressor

To determine which you have:

1. Install high and low side gauge set.
2. Try to start the compressor.
3. Watch the pressures closely.
 - If the pressures do not move, the compressor is seized. Replace the compressor.
 - If the pressures move, the compressor is turning slowly and is not seized. Check the capacitors and relay.

Compressor Drawing High Amps

The continuous amperage draw on start-up should not be near the maximum fuse size indicated on the serial tag.

The wiring must be correctly sized to minimize voltage drop at compressor start-up. The voltage when the compressor is trying to start must be within $\pm 10\%$ of the nameplate voltage.

Fan Cycle Control

Function

Cycles the fan motor on and off to maintain proper operating discharge pressure.

The fan cycle control closes on an increase, and opens on a decrease in discharge pressure.

Specifications

Model	Cut-In (Close)	Cut-Out (Open)
KF150 K170	275 psig \pm 5	225 psig \pm 5
KF250 K270	250 psig \pm 5	200 psig \pm 5

Check Procedure

1. Disconnect electrical power to the ice machine at the electrical service disconnect.
2. Verify fan motor windings are not open or grounded, and fan spins freely.
3. Connect manifold gauge set to ice machine.
4. Hook voltmeter in parallel across the fan cycle control, leaving wires attached.
5. Reconnect electrical power to the ice machine and set the ON/OFF/WASH toggle switch to ON.
6. Wait until water flows over the evaporator then refer to chart below.

System Pressure:	Reading Should Be:	Fan Should Be:
above cut-in	0 volts	running
below cut-out	line voltage	off

High Pressure Cutout (HPCO) Control

Function

Stops the ice machine if subjected to excessive high-side pressure.

The HPCO control is normally closed, and opens on a rise in discharge pressure.

Specifications

Cut-out: 450 psig \pm 10

Cut-in: Automatic reset

(Must be below 300 psig to reset).

Check Procedure

1. Set ON/OFF/WASH switch to OFF.
2. Connect manifold gauge set.
3. Hook voltmeter in parallel across the HPCO, leaving wires attached.
4. On water-cooled models, close the water service valve to the water condenser inlet. On self-contained air-cooled models, disconnect the fan motor.
5. Set ON/OFF/WASH switch to ON.
6. No water or air flowing through the condenser will cause the HPCO control to open because of excessive pressure. Watch the pressure gauge and record the cut-out pressure.

Warning

If discharge pressure exceeds 460 psig and the HPCO control does not cut out, set ON/OFF/WASH switch to OFF to stop ice machine operation.

Replace the HPCO control if it:

- Will not reset (below 300 psig)
- Does not open at the specified cut-out point

Filter-Driers

Liquid Line Filter Drier

The filter-drier used on Koolaire® ice machines are manufactured to Koolaire® specifications.

The difference between a Koolaire® drier and an off-the-shelf drier is in filtration. A Koolaire® drier has dirt-retaining filtration, with fiberglass filters on both the inlet and outlet ends. This is very important because ice machines have a back-flushing action that takes place during every harvest cycle.

A Koolaire® filter-drier has a very high moisture removal capability and a good acid removal capacity.

Important

The liquid line drier is covered as a warranty part. The liquid line drier must be replaced any time the system is opened for repair.

Refrigerant Recovery/Evacuation

Definitions

Recover

To remove refrigerant, in any condition, from a system and store it in an external container, without necessarily testing or processing it in any way.

Recycle

To clean refrigerant for re-use by oil separation and single or multiple passes through devices, such as replaceable core filter-driers, which reduce moisture, acidity and particulate matter. This term usually applies to procedures implemented at the field job site or at a local service shop.

Reclaim

To reprocess refrigerant to new product specifications (see below) by means which may include distillation. A chemical analysis of the refrigerant is required after processing to be sure that product specifications are met. This term usually implies the use of processes and procedures available only at a reprocessing or manufacturing facility.

Chemical analysis is the key requirement in this definition. Regardless of the purity levels reached by a reprocessing method, refrigerant is not considered “reclaimed” unless it has been chemically analyzed and meets ARI Standard 700 (latest edition).

New Product Specifications

This means ARI Standard 700 (latest edition). Chemical analysis is required to assure that this standard is met.

REFRIGERANT RE-USE POLICY

Koolaire® recognizes and supports the need for proper handling, re-use, and disposal of CFC and HCFC refrigerants. Koolaire® service procedures require recapturing refrigerants, not venting them to the atmosphere.

It is not necessary, in or out of warranty, to reduce or compromise the quality and reliability of your customers' products to achieve this.

Important

Koolaire® assumes no responsibility for use of contaminated refrigerant. Damage resulting from the use of contaminated, recovered, or recycled refrigerant is the sole responsibility of the servicing company.

Koolaire® approves the use of:

1. New Refrigerant
 - Must be of original nameplate type.
2. Reclaimed Refrigerant
 - Must be of original nameplate type.
 - Must meet ARI Standard 700 (latest edition) specifications.
3. Recovered or Recycled Refrigerant
 - Must be recovered or recycled in accordance with current local, state and federal laws.
 - Must be recovered from and re-used in the same Koolaire® product. Re-use of recovered or recycled refrigerant from other products is not approved.
 - Recycling equipment must be certified to ARI Standard 740 (latest edition) and be maintained to consistently meet this standard.

4. Recovered refrigerant must come from a “contaminant-free” system. To decide whether the system is contaminant free, consider:
 - Type(s) of previous failure(s)
 - Whether the system was cleaned, evacuated and recharged properly following failure(s)
 - Whether the system has been contaminated by this failure
 - Compressor motor burnouts and improper past service prevent refrigerant re-use.
 - Refer to “System Contamination Cleanup” on page 112 to test for contamination.
5. “Substitute” or “Alternative” Refrigerant
 - Must use only Koolaire®-approved alternative refrigerants.
 - Must follow Koolaire®-published conversion procedures.

RECOVERY AND RECHARGING PROCEDURES

Do not purge refrigerant to the atmosphere. Capture refrigerant using recovery equipment. Follow the manufacturer's recommendations.

Important

Koolaire® assumes no responsibility for the use of contaminated refrigerant. Damage resulting from the use of contaminated refrigerant is the sole responsibility of the servicing company.

Important

Replace the liquid line drier before evacuating and recharging. Use only a OEM liquid line filter drier to prevent voiding the warranty.

CONNECTIONS

1. Suction side of the compressor through the suction service valve.
2. Discharge side of the compressor through the discharge service valve.

SELF-CONTAINED RECOVERY/EVACUATION

1. Place the toggle switch in the OFF position.
2. Install manifold gauge set, charging cylinder/scale, and recovery unit or two-stage vacuum pump.
3. Open (backseat) the high and low side ice machine service valves, and open high and low side on manifold gauge set.
4. Perform recovery or evacuation:
 - A. Recovery: Operate the recovery unit as directed by the manufacturer's instructions.
 - B. Evacuation prior to recharging: Pull the system down to 500 microns. Then, allow the pump to run for an additional half hour. Turn off the pump and perform a standing vacuum leak check.

NOTE: Check for leaks using a halide or electronic leak detector after charging the ice machine.

Follow the Charging Procedures below.

CHARGING PROCEDURES

Important

The charge is critical on all Koolaire® ice machines. Use a scale or a charging cylinder to ensure the proper charge is installed.

1. Be sure the toggle switch is in the OFF position.
2. Close the vacuum pump valve, the low side service valve, and the low side manifold gauge valve.
3. Open the high side manifold gauge valve, and backseat the high side service valve.
4. Open the charging cylinder and add the proper refrigerant charge (shown on nameplate) through the discharge service valve.
5. Let the system "settle" for 2 to 3 minutes.
6. Place the toggle switch in the ICE position.

7. Close the high side on the manifold gauge set. Add any remaining vapor charge through the suction service valve (if necessary).

NOTE: Manifold gauge set must be removed properly to ensure that no refrigerant contamination or loss occurs.

8. Make sure that all of the vapor in the charging hoses is drawn into the ice machine before disconnecting the charging hoses.
 - A. Run the ice machine in freeze cycle.
 - B. Close the high side service valve at the ice machine.
 - C. Open the low side service valve at the ice machine (when supplied) or disconnect the low loss fitting from the access valve.
 - D. Open the high and low side valves on the manifold gauge set. Any refrigerant in the lines will be pulled into the low side of the system.
 - E. Allow the pressures to equalize while the ice machine is in the freeze cycle.
 - F. Close the low side service valve at the ice machine.
9. Remove the hoses from the ice machine and install the caps.

System Contamination Cleanup

General

This section describes the basic requirements for restoring contaminated systems to reliable service.

Important

Koolaire® assumes no responsibility for the use of contaminated refrigerant. Damage resulting from the use of contaminated refrigerant is the sole responsibility of the servicing company.

Determining Severity of Contamination

System contamination is generally caused by either moisture or residue from compressor burnout entering the refrigeration system.

Inspection of the refrigerant usually provides the first indication of system contamination. Obvious moisture or an acrid odor in the refrigerant indicates contamination.

If either condition is found, or if contamination is suspected, use a Total Test Kit from Totaline or a similar diagnostic tool. These devices sample refrigerant, eliminating the need to take an oil sample. Follow the manufacturer's directions.

If a refrigerant test kit indicates harmful levels of contamination, or if a test kit is not available, inspect the compressor oil.

1. Remove the refrigerant charge from the ice machine.
2. Remove the compressor from the system.
3. Check the odor and appearance of the oil.
4. Inspect open suction and discharge lines at the compressor for burnout deposits.
5. If no signs of contamination are present, perform an acid oil test to determine the type of cleanup required.

Contamination/Cleanup Chart	
Symptoms/Findings	Required Cleanup Procedure
No symptoms or suspicion of contamination	Normal evacuation/ recharging procedure
Moisture/Air Contamination symptoms Refrigeration system open to atmosphere for longer than 15 minutes Refrigeration test kit and/or acid oil test shows contamination No burnout deposits in open compressor lines	Mild contamination cleanup procedure
Mild Compressor Burnout symptoms Oil appears clean but smells acrid Refrigeration test kit or acid oil test shows harmful acid content No burnout deposits in open compressor lines	Mild contamination cleanup procedure
Severe Compressor Burnout symptoms Oil is discolored, acidic, and smells acrid Burnout deposits found in the compressor, lines, and other components	Severe contamination cleanup procedure

MILD SYSTEM CONTAMINATION CLEANUP PROCEDURE

1. Replace any failed components.
2. If the compressor is good, change the oil.
3. Replace the liquid line drier.

NOTE: If the contamination is from moisture, use heat lamps during evacuation. Position them at the compressor, condenser and evaporator prior to evacuation. Do not position heat lamps too close to plastic components, or they may melt or warp.

Important

Dry nitrogen is recommended for this procedure. This will prevent CFC release.

4. Follow the normal evacuation procedure, except replace the evacuation step with the following:
 - A. Pull vacuum to 1000 microns. Break the vacuum with dry nitrogen and sweep the system. Pressurize to a minimum of 5 psig.
 - B. Pull vacuum to 500 microns. Break the vacuum with dry nitrogen and sweep the system. Pressurize to a minimum of 5 psig.
 - C. Change the vacuum pump oil.
 - D. Pull vacuum to 500 microns. Run the vacuum pump for 1/2 hour on self-contained models, 1 hour on remotes.

NOTE: You may perform a pressure test as a preliminary leak check. You should use an electronic leak detector after system charging to be sure there are no leaks.

5. Charge the system with the proper refrigerant to the nameplate charge.
6. Operate the ice machine.

SEVERE SYSTEM CONTAMINATION CLEANUP PROCEDURE

1. Remove the refrigerant charge.
2. Remove the compressor.
3. Disassemble the harvest solenoid valve. If burnout deposits are found inside the valve, install a rebuild kit, and replace the TXV and head pressure control valve.
4. Wipe away any burnout deposits from suction and discharge lines at compressor.
5. Sweep through the open system with dry nitrogen.

Important

Refrigerant sweeps are not recommended, as they release CFC into the atmosphere.

Dry nitrogen is recommended for this procedure. This will prevent CFC release.

6. Install a new compressor and new start components.
7. Install suction line filter-drier in front of compressor.
8. Install a new liquid line drier.
9. Follow the normal evacuation procedure, except replace the evacuation step with the following:
 - A. Pull vacuum to 1000 microns. Break the vacuum with dry nitrogen and sweep the system. Pressurize to a minimum of 5 psig.
 - B. Change the vacuum pump oil.
 - C. Pull vacuum to 500 microns. Break the vacuum with dry nitrogen and sweep the system. Pressurize to a minimum of 5 psig.
 - D. Change the vacuum pump oil.
 - E. Pull vacuum to 500 microns. Run the vacuum pump for 1 additional hour.
10. Charge the system with the proper refrigerant to the nameplate charge.

11. Operate the ice machine for one hour. Then, check the pressure drop across the suction line filter-drier.
 - A. If the pressure drop is less than 2 psig, the filter-drier should be adequate for complete cleanup.
 - B. If the pressure drop exceeds 2 psig, change the suction line filter-drier and the liquid line drier. Repeat until the pressure drop is acceptable.
12. Operate the ice machine for 48 – 72 hours. Replace the suction line and liquid line drier if necessary.
13. Follow normal evacuation procedures.

REPLACING PRESSURE CONTROLS WITHOUT REMOVING REFRIGERANT CHARGE

This procedure reduces repair time and cost. Use it when any of the following components require replacement, and the refrigeration system is operational and leak-free.

- Fan cycle control
- High pressure cut-out control
- High side access valve
- Low side access valve

Important

This is a required in-warranty repair procedure.

1. Disconnect power to the ice machine.
2. Follow all manufacturers' instructions supplied with the pinch-off tool. Position the pinch-off tool around the tubing as far from the pressure control as feasible. (See the figure on next page.) Clamp down on the tubing until the pinch-off is complete.

Warning

Do not unsolder a defective component. Cut it out of the system. Do not remove the pinch-off tool until the new component is securely in place.

3. Cut the tubing of the defective component with a small tubing cutter.
4. Solder the replacement component in place. Allow the solder joint to cool.
5. Remove the pinch-off tool.
6. Re-round the tubing. Position the flattened tubing in the proper hole in the pinch off tool. Tighten the wing nuts until the block is tight and the tubing is rounded.

NOTE: The pressure controls will operate normally once the tubing is re-rounded. Tubing may not re-round 100%.

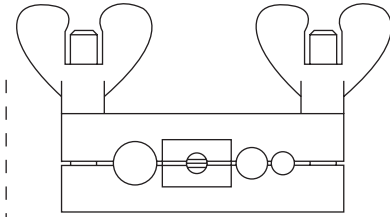

FIG. A - "PINCHING OFF" TUBING

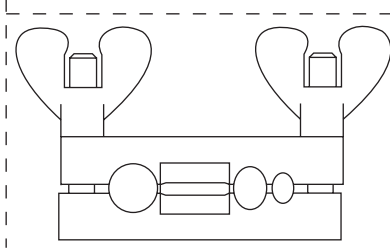

FIG. B - RE-ROUNDING TUBING

SV1406

Using Pinch Off Tool

KF250/K270 Condenser Fan Motor Access

Access to remove, clean or replace the condenser fan/motor can be obtained by performing the following:

1. Disconnect electrical power to the ice machine at the electrical service disconnect.
2. Remove the screws that secure the condenser to the cabinet and the base to the cabinet.
3. Slide the base forward until contact is made with the stop screw (approximately 2.5" [6.3 cm]).

Caution

Do not move base past the stop screw, tubing damage could result.

4. Remove right hand screw securing condenser to base.
5. Pivot condenser forward to obtain 5" (12.7 cm) between the cabinet and condenser shroud. Take care not to kink refrigeration tubing.

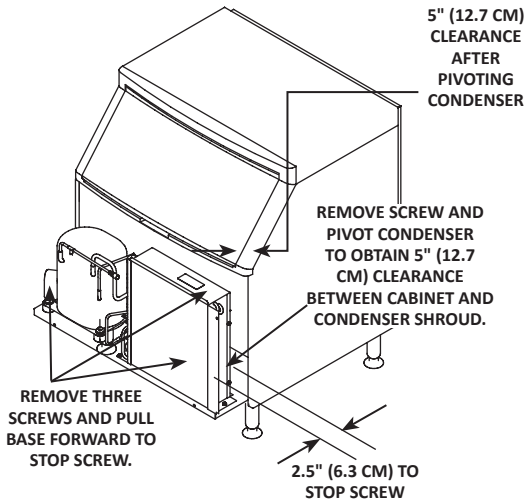

PT1295A

Accessing the Condenser Fan Motor

THIS PAGE INTENTIONALLY LEFT BLANK

Component Specifications

Main Fuse

	Volt	Amp
KF150 K170 KF250 K270	250	10

Bin Switch

Bin switch operation is controlled by the movement of the ice damper.

ON/OFF/WASH Toggle Switch

Single-pole, double-throw switch. The switch is connected into a varying low D.C. voltage circuit.

Fan Control Cycle

Model	Cut-in (Close)	Cut-out (Open)
KF150 K170	275 psig \pm 5	225 psig \pm 5
KF250 K270	250 psig \pm 5	200 psig \pm 5

High Pressure Cutout (HPCO) Control

Cut-out	Cut-in
450 psig \pm 10 (3103 kPa \pm 69) 31 bar \pm .69	Automatic Reset
Must be below 300 psig (2068 kPa, 20.68 bar) to reset.	

Filter-Driers

Drier with dirt-retaining filtration.

Total System Refrigerant Charge

Important

This information is for reference only. Refer to the ice machine serial number tag to verify the system charge. Serial plate information overrides information listed on this page.

Model	Air-Cooled	Water-Cooled	Refrigerant Type
KF150	14 oz (397 g)	NA	R404A
K170	14 oz (397 g)	NA	R404A
KF250	18 oz (510 g)	NA	R404A
K270	22 oz (624 g)	16 oz (454 g)	R404A

Charts

Cycle Times, 24 Hr. Ice Production and Refrigerant Pressure Charts

These charts are used as guidelines to verify correct ice machine operation.

Accurate collection of data is essential to obtain the correct diagnosis.

- Refer to “Operational Analysis Chart” for the list of data that must be collected for refrigeration diagnostics. This list includes: before beginning service, ice production check, installation/visual inspection, water system checklist, ice formation pattern, safety limits, comparing evaporator inlet/outlet temperatures, harvest valve analysis, discharge and suction pressure analysis.
- Ice production checks that are within 10% of the chart are considered normal. This is due to variances in water and air temperature. Actual temperatures will seldom match the chart exactly.
- Zero out manifold gauge set before obtaining pressure readings to avoid misdiagnosis.
- Discharge and suction pressure are highest at the beginning of the cycle. Suction pressure will drop throughout the cycle. Verify the pressures are within the range indicated.
- Production and cycle times are for dice cube - Half dice cube cycle times can be 2 - 3 minutes faster, depending on model and ambient temperature.

KF0150A SELF-CONTAINED AIR-COOLED

NOTE: These characteristics may vary depending on operating conditions.

Cycle Times

Freeze Time + Harvest Time = Total Cycle Time

Air Temp. Entering Condenser °F/°C	Freeze Time			Harvest Time
	Water Temperature °F/°C			
	50/10	70/21	90/32	
70/21	19.8-22.5	21.2-24.0	26.6-30.2	1.0-2.5
80/27	21.2-24.0	22.7-25.8	29.1-32.9	
90/32	23.6-26.8	26.6-30.2	30.4-34.5	
100/38	27.8-31.5	32.0-36.2	37.5-42.5	
110/43	35.5-40.2	42.4-48.0	52.6-59.4	

Times in minutes

24 Hour Ice Production

Air Temp. Entering Condenser °F/°C	Water Temperature °F/°C		
	50/10	70/21	90/32
70/21	165	155	125
80/27	155	145	115
90/32	140	125	110
100/38	120	105	90
110/43	95	80	65

Based on average ice slab weight of 2.44 – 2.75 lb (1107 – 1247 g).
Regular cube derate is 7%

Operating Pressures

Air Temp. Entering Condenser °F/°C	Freeze Cycle		Harvest Cycle	
	Discharge Pressure PSIG	Suction Pressure PSIG	Discharge Pressure PSIG	Suction Pressure PSIG
50/10	220-280	60-38	150-170	90-110
70/21	220-280	60-38	150-170	95-115
80/27	240-290	70-38	160-190	100-120
90/32	280-330	75-38	180-210	160-140
100/38	310-380	85-41	200-230	120-160
110/43	315-390	90-41	200-240	140-170

Suction pressure drops gradually throughout the freeze cycle

K170A SELF-CONTAINED AIR-COOLED

NOTE: These characteristics may vary depending on operating conditions.

Cycle Times

Freeze Time + Harvest Time = Total Cycle Time

Air Temp. Entering Condenser °F/°C	Freeze Time			Harvest Time
	Water Temperature °F/°C			
	50/10	70/21	90/32	
70/21	17.6-20.1	20.5-23.3	24.5-28.0	1.0-2.5
80/27	19.8-22.5	20.9-23.9	27.8-31.5	
90/32	20.9-23.9	24.5-28.0	28.1-31.9	
100/38	25.5-29.0	30.4-34.5	33.7-38.3	
110/43	32.0-36.2	39.8-45.1	48.7-55.1	

Times in minutes

24 Hour Ice Production

Air Temp. Entering Condenser °F/°C	Water Temperature °F/°C		
	50/10	70/21	90/32
70/21	175	160	130
80/27	165	150	120
90/32	150	130	115
100/38	130	110	97
110/43	105	85	70

Based on average ice slab weight of 2.44 – 2.75 lb (1107 – 1247 g).
Regular cube derate is 7%

Operating Pressures

Air Temp. Entering Condenser °F/°C	Freeze Cycle		Harvest Cycle	
	Discharge Pressure PSIG	Suction Pressure PSIG	Discharge Pressure PSIG	Suction Pressure PSIG
50/10	220-280	60-38	150-170	90-110
70/21	220-280	60-38	150-170	95-115
80/27	240-290	70-38	160-190	100-120
90/32	280-330	75-38	180-210	160-140
100/38	310-380	85-41	200-230	120-160
110/43	315-390	90-41	200-240	140-170

Suction pressure drops gradually throughout the freeze cycle

KF0250 SELF-CONTAINED AIR-COOLED

NOTE: These characteristics may vary depending on operating conditions.

Cycle Times

Freeze Time + Harvest Time = Total Cycle Time

Air Temp. Entering Condenser °F/°C	Freeze Time			Harvest Time
	Water Temperature °F/°C			
	50/10	70/21	90/32	
70/21	12.3-14.0	14.5-16.5	16.5-18.8	1.0-2.5
80/27	13.1-15.5	15.2-17.4	17.5-19.9	
90/32	14.1-16.1	18.0-20.5	20.5-23.3	
100/38	15.2-17.4	21.2-24.0	24.5-27.8	
110/43	16.5-18.8	25.5-29.0	30.4-34.5	

Times in minutes

24 Hour Ice Production

Air Temp. Entering Condenser °F/°C	Water Temperature °F/°C		
	50/10	70/21	90/32
70/21	255	220	195
80/27	240	210	185
90/32	225	180	160
100/38	210	155	135
110/43	195	130	110

Based on average ice slab weight of 2.44 – 2.75 lb (1107 – 1247 g).

Operating Pressures

Air Temp. Entering Condenser °F/°C	Freeze Cycle		Harvest Cycle	
	Discharge Pressure PSIG	Suction Pressure PSIG	Discharge Pressure PSIG	Suction Pressure PSIG
50/10	200-255	60-22	165-200	70-95
70/21	200-255	60-23	170-205	70-100
80/27	200-290	60-24	175-210	75-100
90/32	235-320	65-25	200-240	80-105
100/38	260-370	70-31	215-255	85-120
110/43	310-365	80-42	230-270	110-130

Suction pressure drops gradually throughout the freeze cycle

K270 SELF-CONTAINED AIR-COOLED

NOTE: These characteristics may vary depending on operating conditions.

Cycle Times

Freeze Time + Harvest Time = Total Cycle Time

Air Temp. Entering Condenser °F/°C	Freeze Time			Harvest Time
	Water Temperature °F/°C			
	50/10	70/21	90/32	
70/21	11.0-12.6	12.8-14.7	14.5-16.5	1.0-2.5
80/27	11.3-12.9	13.1-15.0	14.8-16.9	
90/32	12.6-14.3	14.8-16.9	17.0-19.3	
100/38	14.1-16.1	17.0-19.3	19.8-22.5	
110/43	15.2-17.4	19.8-22.5	23.6-26.8	

Times in minutes

24 Hour Ice Production

Air Temp. Entering Condenser °F/°C	Water Temperature °F/°C		
	50/10	70/21	90/32
70/21	280	245	220
80/27	275	240	215
90/32	250	215	190
100/38	225	190	165
110/43	210	165	140

Based on average ice slab weight of 2.44 – 2.75 lb (1107 – 1247 g).
Regular cube derate is 7%

Operating Pressures

Air Temp. Entering Condenser °F/°C	Freeze Cycle		Harvest Cycle	
	Discharge Pressure PSIG	Suction Pressure PSIG	Discharge Pressure PSIG	Suction Pressure PSIG
50/10	200-255	60-22	165-200	70-95
70/21	200-255	60-22	170-205	70-100
80/27	200-295	61-23	175-210	75-100
90/32	240-330	65-26	205-240	80-100
100/38	265-375	66-30	220-260	85-115
110/43	320-380	80-42	230-275	115-135

Suction pressure drops gradually throughout the freeze cycle

K270 SELF-CONTAINED WATER-COOLED

NOTE: These characteristics may vary depending on operating conditions.

Cycle Times

Freeze Time + Harvest Time = Total Cycle Time

Air Temp. Around Ice Machine °F/°C	Freeze Time			Harvest Time
	Water Temperature °F/°C			
	50/10	70/21	90/32	
70/21	10.6-12.2	12.3-14.0	13.5-15.4	1.0-2.5
80/27	10.8-12.4	12.6-14.3	13.8-15.7	
90/32	11.0-12.6	12.8-14.7	14.1-16.1	
100/38	11.3-12.9	13.1-15.0	14.5-16.5	

Times in minutes

24 Hour Ice Production

Air Temp. Around Ice Machine °F/°C	Water Temperature °F/°C		
	50/10	70/21	90/32
70/21	290	255	235
80/27	285	250	230
90/32	280	245	225
100/38	275	240	220

Based on average ice slab weight of 2.44 – 2.75 lb (1107 – 1247 g).
Regular cube derate is 7%

Condenser Water Consumption	90/32 Air Temperature Around Ice Machine		
	Water Temperature °F/°C		
	50/10	70/21	90/32
Gal/24 hours	240	410	2740

Water regulating valve set to maintain 240 PSIG discharge pressure

Operating Pressures

Air Temp. Around Ice Machine °F/°C	Freeze Cycle		Harvest Cycle	
	Discharge Pressure PSIG	Suction Pressure PSIG	Discharge Pressure PSIG	Suction Pressure PSIG
50/10	235-245	52-24	175-210	80-95
70/21	235-245	54-24	175-210	80-95
80/27	235-250	56-24	175-210	80-95
90/32	235-255	58-24	175-210	80-95
100/38	235-260	60-24	175-210	80-95

Suction pressure drops gradually throughout the freeze cycle

Diagrams

Wiring Diagrams

The following pages contain electrical wiring diagrams. Be sure you are referring to the correct diagram for the ice machine you are servicing.

Warning

Always disconnect power before working on electrical circuitry.

Wiring Diagram Legend

The following symbols are used on all of the wiring diagrams:

- * Internal Compressor Overload
(Some models have external compressor overloads)
- ** Fan Motor Run Capacitor
(Some models do not incorporate fan motor run capacitor)
- () Wire Number Designation
(The number is marked at each end of the wire)
- >>— Multi-pin Connection
(Electrical Box Side) —>>—
(Compressor Compartment Side)

KF150/K170 WIRING DIAGRAM

NOTE: Diagram shown in the freeze cycle

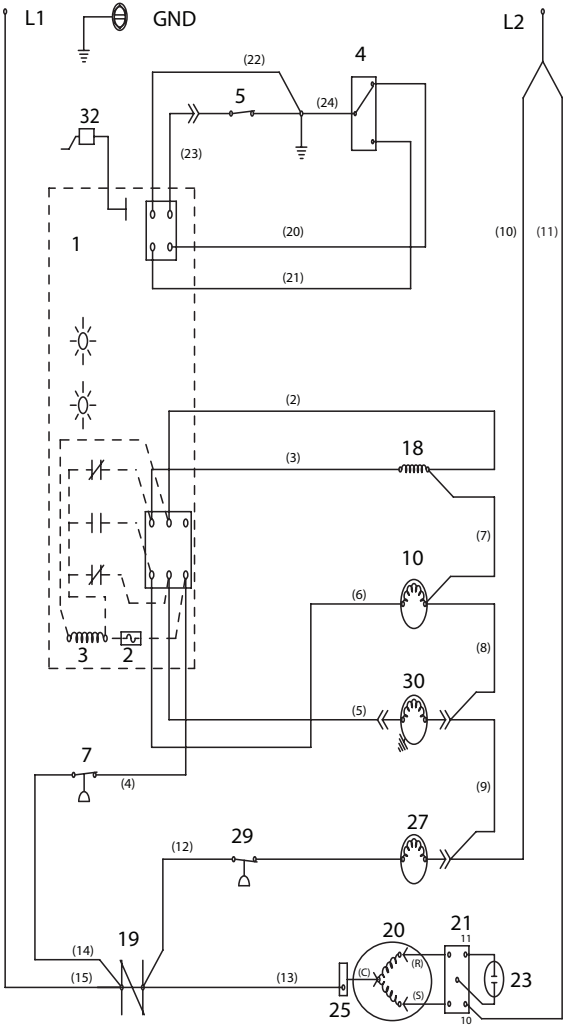

1	Control Board
2	Fuse
3	Transformer
4	On/Off /Clean Switch
5	Bin Switch
6	Bin Thermostat
7	High Pressure Cut Out
10	Harvest Solenoid Valve
18	Contactora Coil
19	Contactora Contacts
20	Compressor
21	Compressor Relay
23	Compressor Start Capacitor
25	Compressor Overload
27	Condenser Fan Motor
29	Fan Cycle Control
30	Water Pump
32	Ice Thickness Control

KF250/K270 WIRING DIAGRAM

NOTE: Diagram shown in the freeze cycle

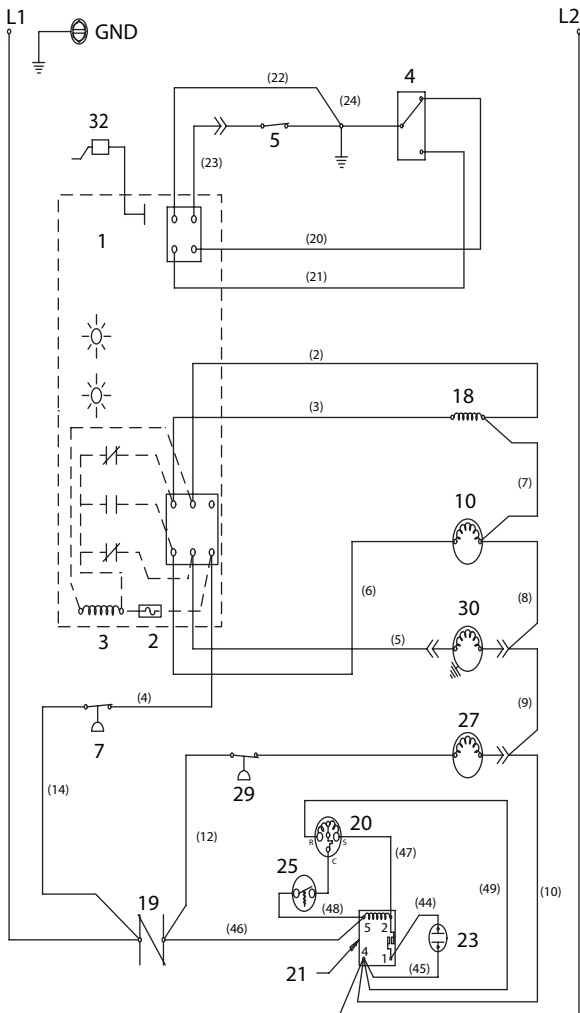

1	Control Board
2	Fuse
3	Transformer
4	On/Off /Clean Switch
5	Bin Switch
6	Bin Thermostat
7	High Pressure Cut Out
10	Harvest Solenoid Valve
18	Contactora Coil
19	Contactora Contacts
20	Compressor
21	Compressor Potential Relay
23	Compressor Start Capacitor
25	Compressor Overload - May be internal or external
27	Condenser Fan Motor
29	Fan Cycle Control
30	Water Pump
32	Ice Thickness Control

Electronic Control Board

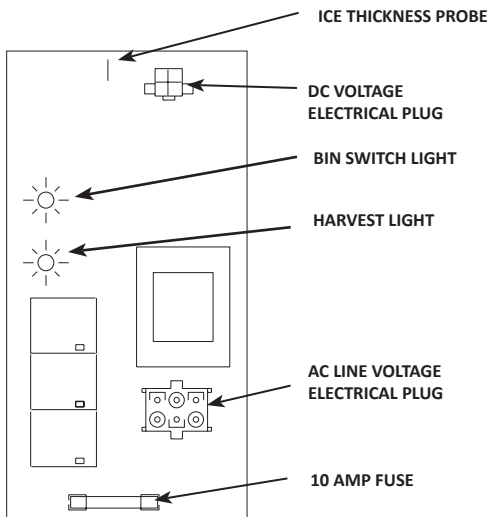

KF150/K170/KF250/K270 Tubing Schematic

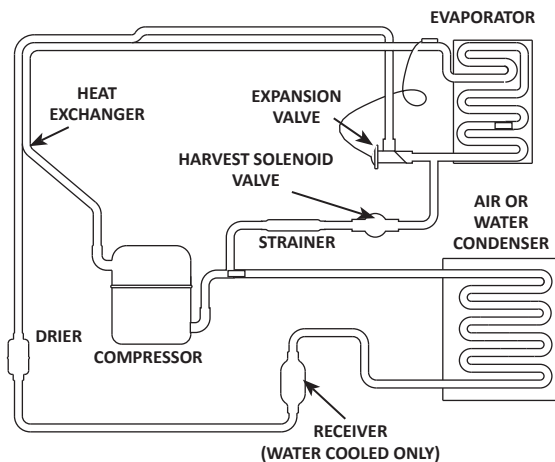

SV3023

KOOLAIRE®

KOOLAIRE
ICE MACHINE DIVISION
2110 SOUTH 26TH STREET
MANITOWOC, WI 54220

800-545-5720
WWW.KOOL-AIRE.COM

Every new piece of Welbilt equipment comes with KitchenCare™ and you choose the level of service that meets your operational needs from one restaurant to multiple locations.



StarCare – Warranty & lifetime service, certified OEM parts, global parts inventory, performance audited

ExtraCare – CareCode, 24/7 Support, online/mobile product information

LifeCare – Install & equipment orientation, planned maintenance, KitchenConnect™, MenuConnect

Talk with KitchenCare™ • 1-844-724-CARE • www.welbilt.com

To learn how Welbilt and its leading brands can equip you, visit our global website



www.manitowocfoodservice.com, then discover the regional or local resources available to you.