

# QuietQube<sup>®</sup> iF2100C Remote Ice Cube Machine

Air-Cooled Ice Cube Machine with Patented CVD Technology<sup>®</sup>

## Models

- IDF2100C     IYF2100C



IDF2100C Ice Cube Machine - 115V



CVDF2100 Condensing Unit



IDF2100C  
Ice Machine  
on a D-970 Bin

Two IDF2100C  
Ice Machines  
on a F-1650 Bin

## Standard Features

QuietQube Series Remote System consists of a remote condensing unit, interconnecting refrigerant lines, ice machine head section along with an ice storage bin, countertop dispenser, or floor dispenser. All ordered separately. QuietQube ice machine with CVD condensing unit is designed as a Manitowoc system and cannot be used with any other ice machine or remote condenser brand.

- **Space-Saving Design** - Up to 1811 lbs. (821 kgs.) daily ice production and only 30" (76.20 cm) wide.
- **Quiet Operation** - eliminates most noise from the refrigeration system. Promotes a relaxing atmosphere.
- **easyTouch<sup>®</sup> Display** - New icon based touch screen takes the guess work out of owning and operating an ice machine.
- **Programmable Ice Production** - Now its super easy to program your ice machine to be off at certain times of the day to save money with fluctuating electrical rates. Also programmable by daily ice production volume.
- **Easy to Clean Foodzone** - Hung door for easy access. Removable water-trough, distribution tube, splash guard, water probe and water pump for fast and efficient cleaning. Selected components are made with AlphaSan<sup>®</sup> antimicrobial.
- **Intelligent Diagnostics** - Provides 24 hour preventative maintenance and diagnostic feedback for trouble free operation.
- **Acoustical Ice Sensing Probe** - Unique patented technology allows for reliable operation in challenging water conditions and environments
- **DuraTech<sup>®</sup> Exterior** - Provides superior corrosion resistant above stainless steel. Innovative clear-coat resists fingerprints and dirt making it easier to keep clean.
- **Available LuminIce<sup>®</sup> II Growth Inhibitor** - Controls the growth of bacteria and yeast within the Food zone keeping the machine cleaner longer. A new indicator in the display keeps you abreast of the operational status.



## Ice Shape

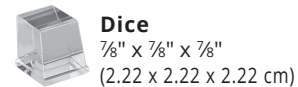
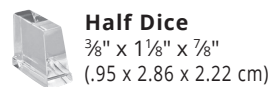

COMPANY WITH  
QUALITY SYSTEM  
CERTIFIED BY DNV  
= ISO 9001:2008 =

QuietQube<sup>®</sup> iF2100C Remote Ice Cube Machine



## iF2100C Ice Machine

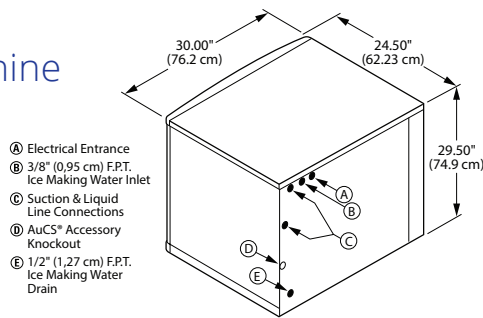

Clearances required:  
2" top, 8" sides, 5" back.

Shipping Weight:  
223 lbs. / 101 kgs.

## Ice Machine Electric

**115/60/1 standard.**

**Total Amps:** 1.1

**Max. fuse size:** 15 amps

HACR-type circuit breakers can be used in place of fuses.

## Specifications

### Operating Limits:

Ambient Temperature Range: 40° to 110° F (4.4° to 43.4° C)

Water Temperature Range: 40° to 90° F (4.4° to 32.2° C)

Water Pressure Ice Maker Water In:

Min. 20 psi (137.9 kPa)

Max. 80 psi (551.1 kPa)

## CVDF2100 Remote Condensing Unit

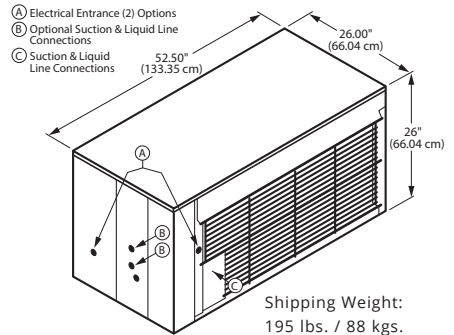

Shipping Weight:  
195 lbs. / 88 kgs.

**208-230/60/1 standard.** 208-230/60/3 also available.

HACR-type circuit breakers can be used in place of fuses.

Note: QuietQube ice machine power supply is wired independent of CVD condensing unit.

### Min. circuit ampacity:

40 1ph

30 3ph

### Max. fuse size:

50 amps 1ph

30 amps 3ph

HACR-type circuit breakers can be used in place of fuses.

### BTU Per Hour:

31,500 (average) 35,500 (peak)

### Compressor:

Nominal rating: 3.5 HP

### Operating Limits:

Ambient Temperature Range:

-20° to 130° F (-29° to 54° C)

### Installation Information and Dimensions:

Maximum Line Length

—100' (30.5 m)\*

Maximum Vertical Rise\*

—35' (10.7 m) above ice machine.

Maximum Vertical Drop

—15' (4.5 m) below ice machine.

\*A rise over 20' (6 m) requires S-Trap Kit K-00166 - ordered separately.

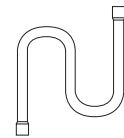

## Remote Air-cooled Ice Machine

Model	Ice Shape	Ice Production 24 Hours		Power kWh/ 100 lbs. @90° Air/70°F*	Potable Water Usage/ 100 lbs. 45.4 kg of Ice*
		70° Air/ 50°F Water	90° Air/ 70°F Water		
IDF-2100C	dice	1,800 lbs.	1,625 lbs.	4.54	18 gal. 68 L
		816 kgs.	737 kgs.		
iYF2100C	half-dice	1,811 lbs.	1,600 lbs.	4.74	18 gal. 68 L
		821 kgs.	726 kgs.		

Ice machine for use with ice dispenser, CVD condensing unit and dispenser adapter. All ordered separately. kWh per 100 lbs. is total power of ice machine and condensing unit. Ice machine is 1 ph only. Condensing unit is 1 ph or 3 ph.



\*Ratings Certified in Accordance with AHRI Standard 810.

## Standard Interconnecting Tubing

Model	Line Length		Weight	
	ft.	m	lbs.	kg
RC-23	20	6.2	17	8
RC-33	30	9.2	25	11
RC-53	50	15.2	39	18

## Accessories

**Luminice® II Growth Inhibitor** reduces yeast and bacteria growth for a cleaner ice machine.



**External Scoop holder**  
Protect the ice scoop with the NSF approved versatile scoop holder.



**iAuCS®**  
Automatic Cleaning System purchased as an option and installed in the field.



Welbilt reserves the right to make changes to the design or specifications without prior notice.