



Item: _____

Quantity: _____

Project: _____

Electric Single and Double Deck Ovens

Electric Single and Double Deck Ovens

Models:

- RRE-36-LB
- RRE-36-LB-C
- RRE-36-DS
- RRE-36-DS-C
- RRE-36-DS-CC



RRE-36-DS-C



RRE-36-LB

Voltage: 208V 240V

Phase: 1 Phase

*Convection Oven:

(For RRE-36-DS-C only) Top Bottom

Standard Features

- Frame constructed of heavy gauge metal solidly welded
- Stainless steel front, sides, top and kick plate
- 4 KW oven heating element
- Oven thermostat controls, 200°-500°F
- Oven contact surfaces have porcelain finish for easy maintenance
- Five position heavy gauge chrome rack guides
- One chrome rack per oven

Options and Accessories

- Additional oven rack
- 5" swivel casters (set of four - 2 locking)
- Seismic flanged feet

Convection Oven Features

- 3 heavy duty chrome plated racks with 5 position adjustment
- Cook and cool switch
- 2 speed (HI/LO) fan switch
- Thermostat adjustable from 150° to 500° F
- One hour manual timer



2 YEAR LIMITED, PARTS AND LABOR WARRANTY

Electric Single and Double Deck Ovens

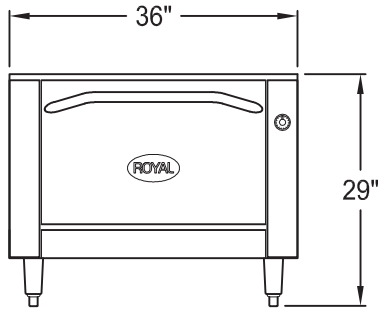

RRE-36-LB

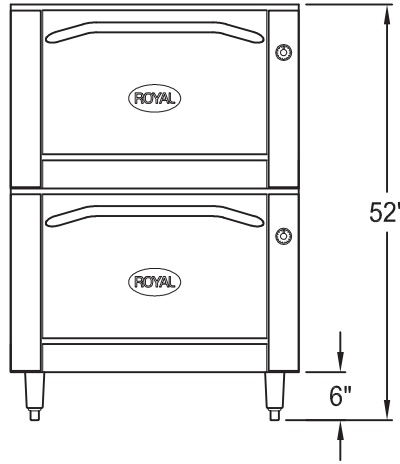

RRE-36-DS

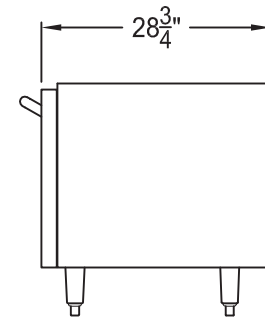

Standard Oven

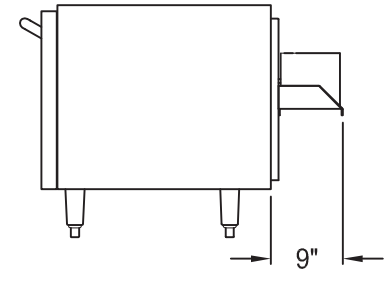

Convection Oven

Model Number	Total KW	Voltage	A M P S		Shipping Weight
			1 Phase		
			L1	L3	
RRE-6-LB	4	208	21	21	185 lbs.
		240	18	18	
RRE-36-LB-C	5.5	208	28	28	205 lbs.
		240	25	25	
RRE-36-DS	8	208	42	42	373 lbs.
		240	36	36	
RRE-36-DS-C	9.5	208	49	49	390 lbs.
		240	43	43	
RRE-36-DS-CC	11	208	56	56	405 lbs.
		240	50	50	

To be installed only in noncombustible surroundings. See installation instructions.

Due to continuing product development to ensure best possible performance, these specifications are subject to change without prior notification.

Royal Range of California, Inc.
 3245 Corridor Dr. • Eastvale, CA 91752 • (800) 769-2414 • (951) 360-1600
 Fax: (951) 360-7500 • www.royalranges.com • sales@royalranges.com